

Application

- Wastewater drainage in factories, construction sites and commercial facilities
- Drainage system in municipal sewage treatment plants
- Drainage station in residential quarters
- Municipal projects
- Methane pools and field irrigation in countryside

Pump

- Max. immersion depth: 5 m
- Max. liquid temperature: +40°C
- Liquid pH value: 4 – 10
- Liquid kinematic viscosity: $7 \times 10^{-7} \sim 23 \times 10^{-6} \text{ m}^2/\text{s}$
- Max. liquid density: $1.2 \times 10^3 \text{ kg/m}^3$

Motor

- Copper winding
- Built-in thermal protector
- Stainless steel welded shaft
- Insulation class: B
- Protection class: IP68

Identification Codes

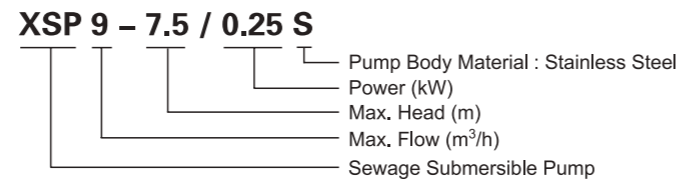

Hydraulic Performance Curves

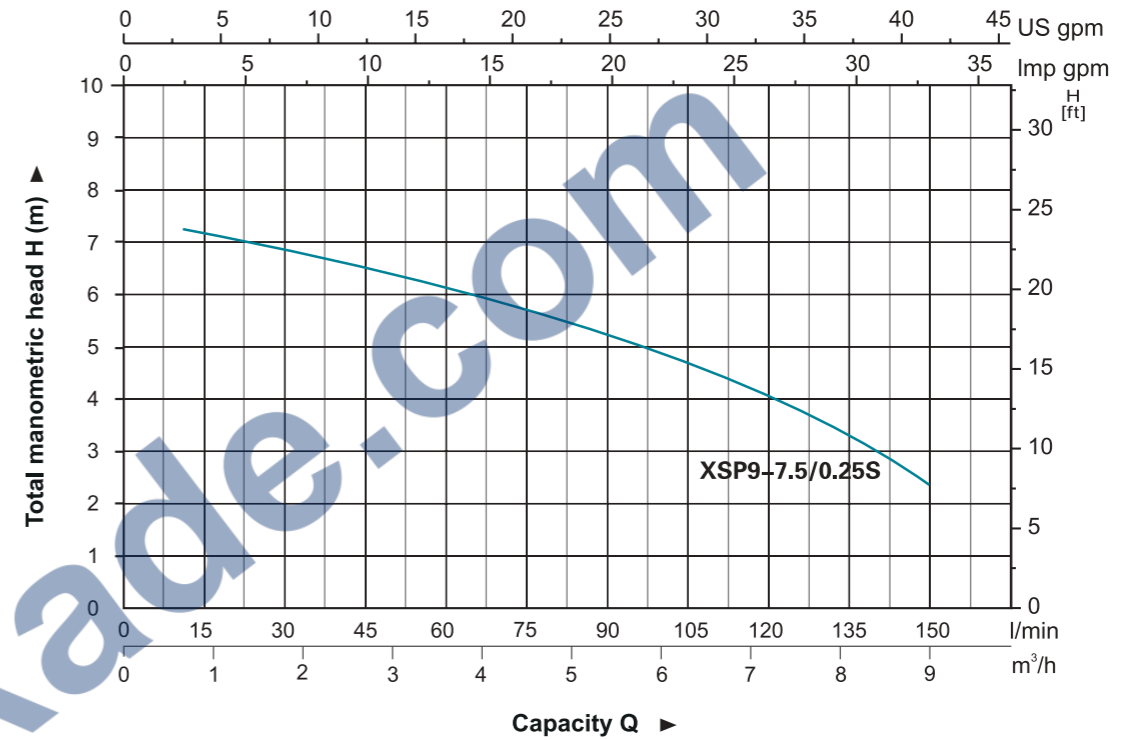

Technical Data

Model	Power		Outlet diameter (mm)	Voltage (V/Hz)	Max. flow (l/min)	Max. head (m)	Max. dia. of particle (mm)	GW (kgs)	Packing size (mm)	Quantity (PCS/20 TEU)
	(kW)	HP								
XSP9-7.5/0.25S	0.25	0.33	40,32,25	220/50	150	7.5	15	10.5	185x180x380	2110

Materials Table

No.	Part	Material	No.	Part	Material
1	Bolt	Stainless steel	25	Stator	Stainless steel
2	Stretching washer	Stainless steel	26	Screw	Stainless steel
3	Washer	Stainless steel	27	Stretching washer	Stainless steel
4	Handle	Stainless steel	28	Thermal protector	Stainless steel
5	Screw	Stainless steel	29	Wave washer	65Mn
6	Cable		30	Ball bearing	
7	Flange	Stainless steel	31	Rotor	
8	Cable protector	CR	32	Ball bearing	
9	Capacitor cover	Stainless steel	33	Rubber washer	FKM
10	Screw	Stainless steel	34	Screw	Stainless steel
11	Cable presser	Stainless steel	35	O-ring	FKM
12	Protector	FKM	36	Connection part	Stainless steel
13	O-ring	NBR	37	Mechanical seal	Carbon/Ceramic
14	Capacitor		38	O-ring	FKM
15	Rubber washer	FKM	39	Oil chamber cover	Stainless steel
16	Screw	Steel	40	Washer	Stainless steel
17	Stretching washer	65Mn	41	Screw	Stainless steel
18	Washer	Steel	42	Oil seal	
19	Press plate	Steel	43	Impeller	Stainless steel
20	Cable holder	NBR	44	Nut	Stainless steel
21	Screw	CuZn40	45	Connector	ABS
22	Stretching washer	65Mn	46	O-ring	FKM
23	Washer	CuZn40	47	Pump body	Stainless steel
24	Nut	Stainless steel			

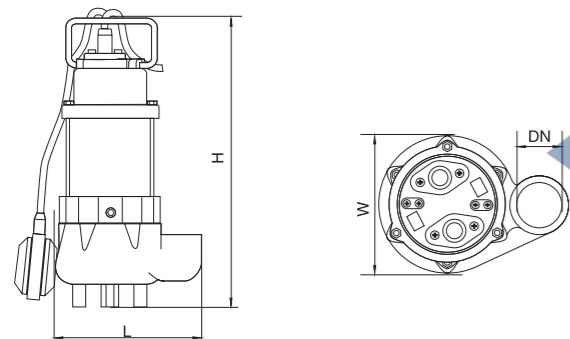
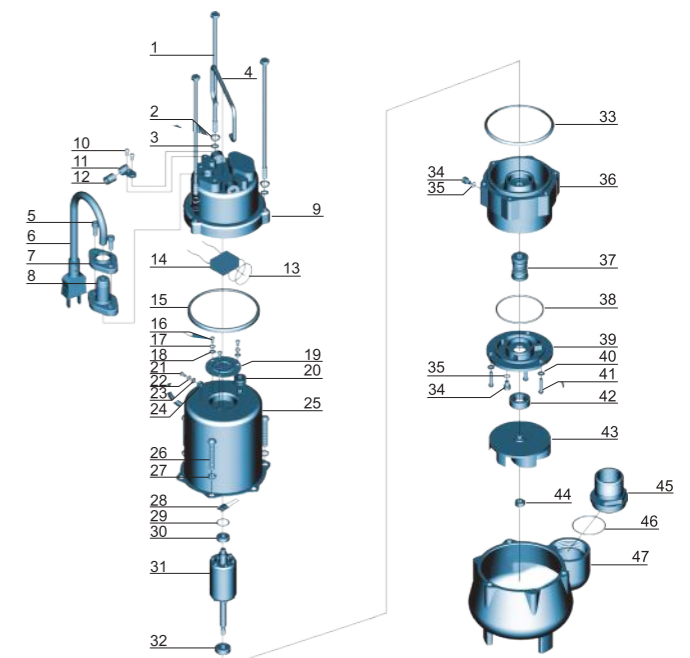

Dimension

Model	DN	L (mm)	W (mm)	H (mm)
XSP9-7.5/0.25S	1 1/4"	165	120	360

Application

- Wastewater drainage in factories, construction sites and commercial facilities
- Drainage system in municipal sewage treatment plants
- Drainage station in residential quarters
- Municipal projects
- Methane pools and field irrigation in countryside

Pump

- Max. immersion depth: 5 m
- Max. liquid temperature: +40°C
- Liquid pH value: 4 – 10
- Liquid kinematic viscosity: $7 \times 10^{-7} \sim 23 \times 10^{-6} \text{ m}^2/\text{s}$
- Max. liquid density: $1.2 \times 10^3 \text{ kg/m}^3$

Motor

- Copper winding
- Built-in thermal protector
- Stainless steel welded shaft
- Insulation class: B
- Protection class: IP68

Identification Codes

XSP 18 - 12 / 0.75 S

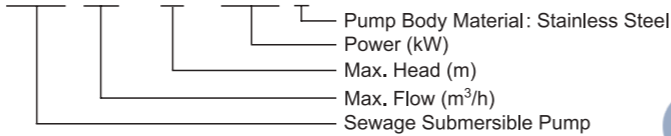

Hydraulic Performance Curves

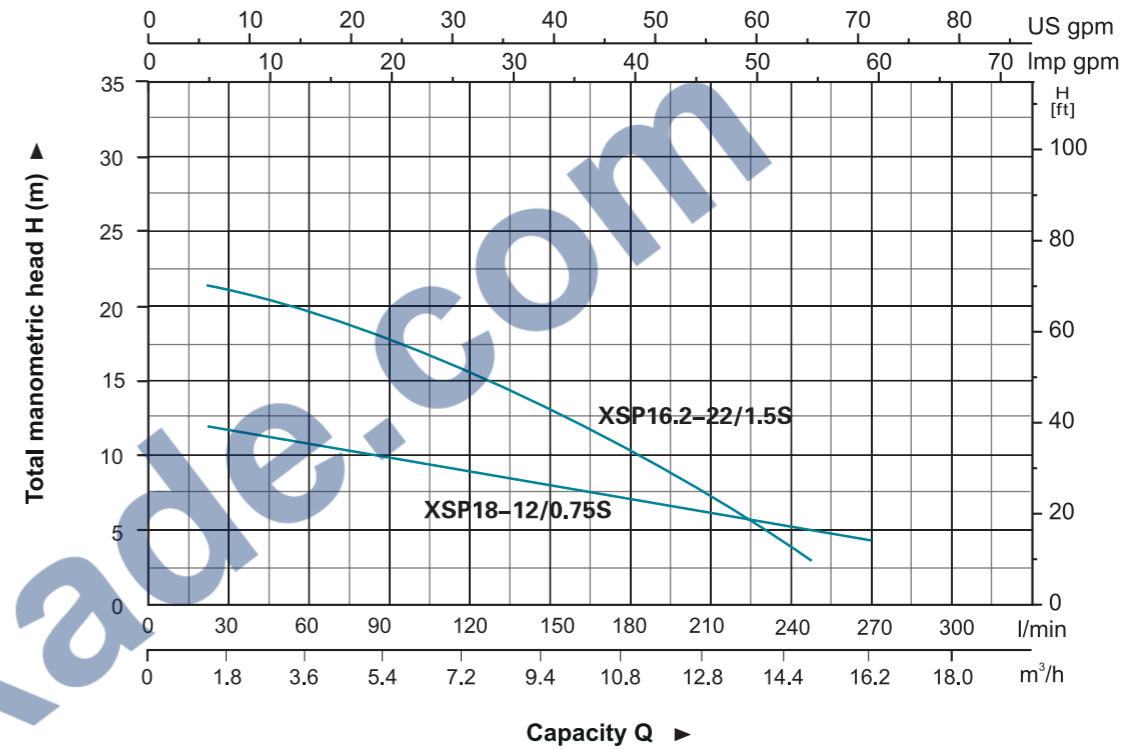

Technical Data

Model	Power		Outlet diameter (mm)	Voltage (V/Hz)	Max. flow (l/min)	Max. head (m)	Max. dia. of particle (mm)	GW (kgs)	Packing size (mm)	Quantity (PCS/20' TEU)
	(kW)	HP								
XSP18-12/0.75S	0.75	1.0	50	220/50	300	12	25	22.2	540x265x195	1056
XSP16.2-22/1.5S	1.5	2.0	40	220/50	270	22	10	27.5	585x350x245	540

Materials Table

No.	Part	Material	No.	Part	Material
1	Bolt	Stainless steel	29	Stator	
2	Stretching washer	Stainless steel	30	Wave washer	65Mn
3	Washer	Stainless steel	31	Ball bearing	
4	Bolt	Stainless steel	32	Rotor	
5	Washer	Stainless steel	33	Ball bearing	
6	Handle	Stainless steel	34	Screw	Stainless steel
7	Nut	Stainless steel	35	Washer	Stainless steel
8	Protector	FKM	36	Connection part	Stainless steel
9	Cable presser	Stainless steel	37	Mechanical seal	Carbon/Ceramic
10	Washer	Stainless steel	38	O-ring	FKM
11	Screw	Stainless steel	39	Oil chamber cover	Stainless steel
12	Bolt	Stainless steel	40	Screw	Stainless steel
13	O-ring	FKM	41	Washer	Stainless steel
14	Bolt	Stainless steel	42	O-ring	FKM
15	Flange	Stainless steel	43	Screw	Stainless steel
16	Cable		44	Oil seal	
17	Cable protector	CR	45	Impeller	Stainless steel
18	Capacitor cover	Stainless steel	46	Nut	
19	Capacitor		47	Bolt	Stainless steel
20	O-ring	NBR	48	Washer	Stainless steel
21	Rubber washer	FKM	49	Connector	ABS
22	Screw	CuZn40	50	O-ring	FKM
23	Stretching washer	65Mn	51	Connection nut	Stainless steel
24	Washer	CuZn40	52	Rubber washer	FKM
25	Cable holder	NBR	53	Pump body	Stainless steel
26	Motor cover	HT200	54	Base plate	Stainless steel
27	Thermal protector		55	Washer	Stainless steel
28	O-ring	FKM	56	Screw	Stainless steel

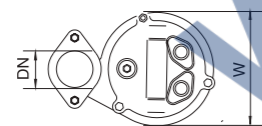
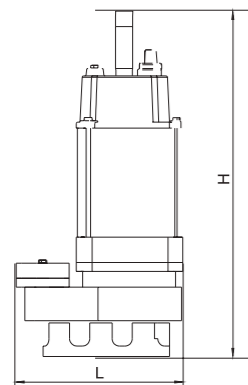
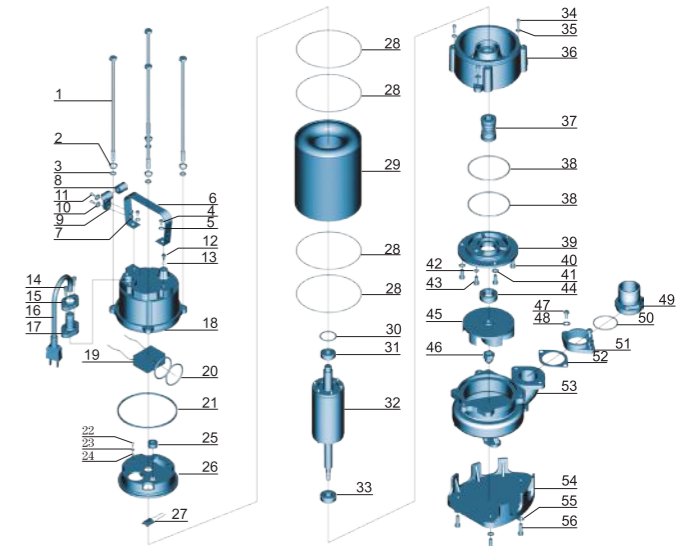

Dimension

Model	DN	L (mm)	W (mm)	H (mm)
XSP18-12/0.75S	2"	226	159	500
XSP16.2-22/1.5S	2"	275	198	530