



Application

- Wastewater drainage in factories, construction sites and commercial facilities
- Drainage system in municipal sewage treatment plants
- Drainage station in residential quarters
- Municipal projects
- Methane pools and field irrigation in countryside

Pump

- Max. immersion depth: 5 m
- Max. liquid temperature: +40°C
- Liquid pH value: 4 – 10
- Liquid kinematic viscosity: $7 \times 10^{-7} \sim 23 \times 10^{-6} \text{ m}^2/\text{s}$
- Max. liquid density: $1.2 \times 10^3 \text{ kg/m}^3$

Motor

- Copper winding
- Built-in thermal protector
- Stainless steel welded shaft
- Insulation class: B
- Protection class: IP68

Identification Codes

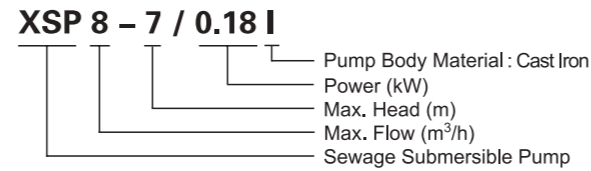

Hydraulic Performance Curves

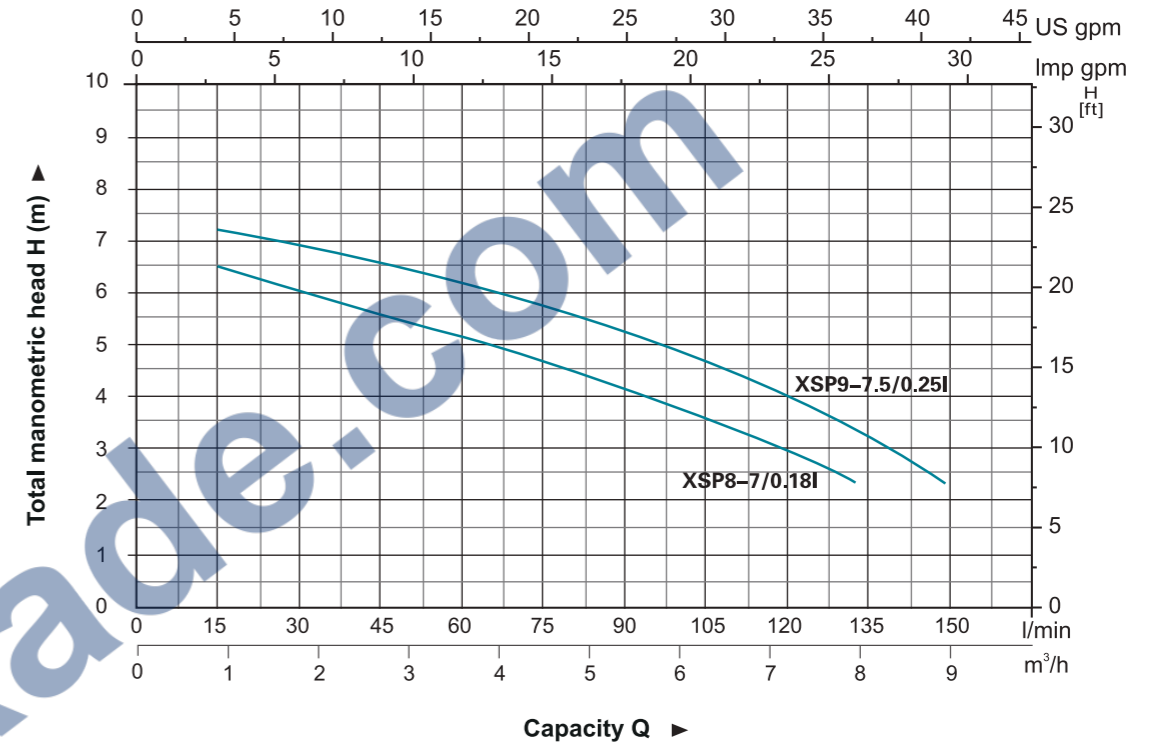

Technical Data

Model	Power		Outlet diameter (mm)	Voltage (V/Hz)	Max.flow (l/min)	Max.head (m)	Max.dia. of particle (mm)	GW (kgs)	Packing size (mm)	Quantity (PCS/20 TEU)
	(kW)	HP								
XSP8-7/0.18I	0.18	0.25	40,32,25	220/50	133	7	15	9	185x180x360	2322
XSP9-7.5/0.25I	0.25	0.33	40,32,25	220/50	150	7.5	15	10	185x180x380	2174

Materials Table

No.	Part	Material	No.	Part	Material
1	Bolt	Stainless steel	25	Stator	
2	Stretching washer	Stainless steel	26	Screw	Stainless steel
3	Washer	Stainless steel	27	Stretching washer	Stainless steel
4	Handle	Stainless steel	28	Thermal protector	
5	Screw	Stainless steel	29	Wave washer	65Mn
6	Cable		30	Ball bearing	
7	Flange	Stainless steel	31	Rotor	
8	Cable protector	CR	32	Ball bearing	
9	Capacitor cover	HT200	33	Rubber washer	NBR
10	Screw	Stainless steel	34	Screw	Stainless steel
11	Cable presser	Stainless steel	35	O-ring	NBR
12	Protector	NR	36	Connection part	HT200
13	O-ring	NBR	37	Mechanical seal	Carbon/Ceramic
14	Capacitor		38	O-ring	NBR
15	Rubber washer	NBR	39	Oil chamber cover	HT200
16	Screw	Steel	40	Washer	Stainless steel
17	Stretching washer	65Mn	41	Screw	Stainless steel
18	Washer	Steel	42	Oil seal	
19	Press plate	Steel	43	Impeller	PA66
20	Cable holder	NBR	44	Nut	Stainless steel
21	Screw	CuZn40	45	Connector	ABS
22	Stretching washer	65Mn	46	O-ring	NBR
23	Washer	CuZn40	47	Pump body	HT200
24	Nut	Stainless steel	48	Float switch	

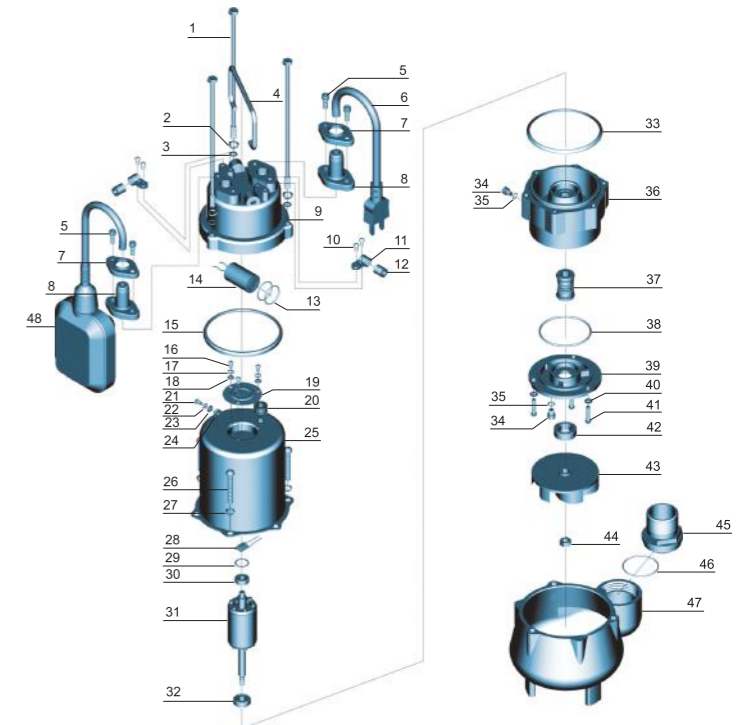

Dimension

Model	DN	L (mm)	W (mm)	H (mm)
XSP8-7/0.18I	1 1/4"	166	121	335
XSP9-7.5/0.25I	1 1/4"	166	121	355

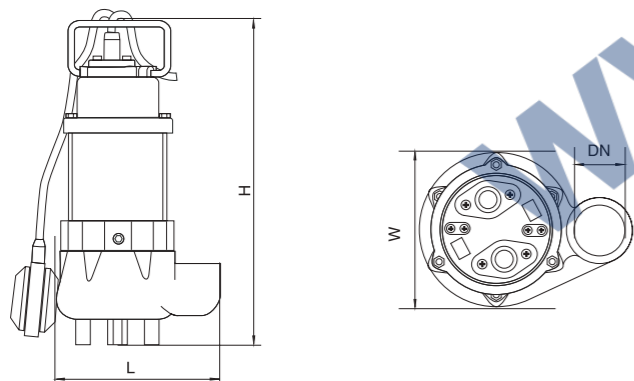

Application

- Wastewater drainage in factories, construction sites and commercial facilities
- Drainage system in municipal sewage treatment plants
- Drainage station in residential quarters
- Municipal projects
- Methane pools and field irrigation in countryside

Pump

- Max. immersion depth: 5 m
- Max. liquid temperature: +40°C
- Liquid pH value: 4 – 10
- Liquid kinematic viscosity: $7 \times 10^{-7} \sim 23 \times 10^{-6} \text{ m}^2/\text{s}$
- Max. liquid density: $1.2 \times 10^3 \text{ kg/m}^3$

Motor

- Copper winding
- Built-in thermal protector
- Stainless steel welded shaft
- Insulation class: B
- Protection class: IP68

Identification Codes

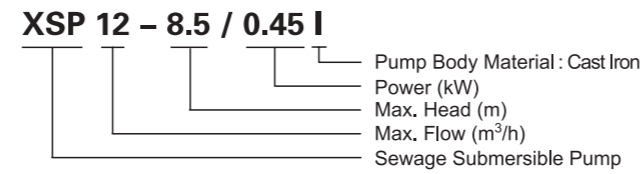

Hydraulic Performance Curves

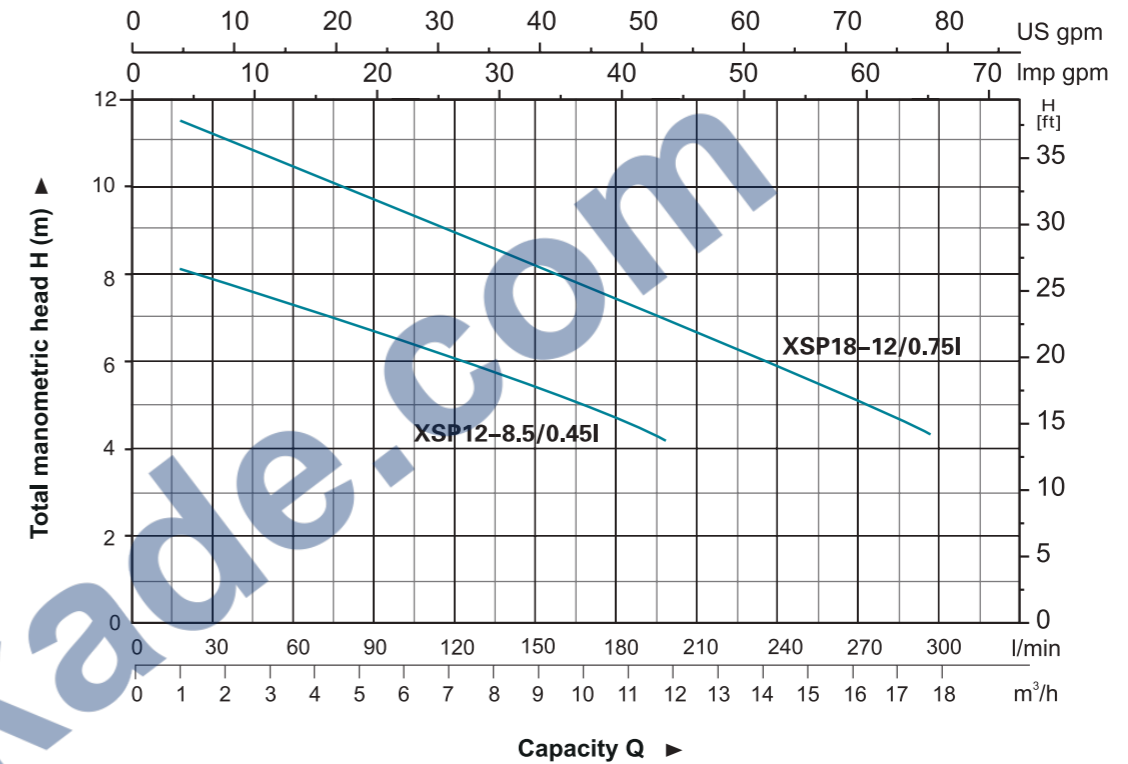

Technical Data

Model	Power		Outlet diameter (mm)	Voltage (V/Hz)	Max. flow (l/min)	Max. head (m)	Max. dia. of particle (mm)	GW (kgs)	Packing size (mm)	Quantity (PCS/20 TEU)
	(kW)	HP								
XSP12-8.5/0.45I	0.45	0.6	50	220/50	200	8.5	25	18.2	495x263x222	1010
XSP18-12/0.75I	0.75	1.0	50	220/50	300	12	25	20.2	540x265x195	1056

Materials Table

No.	Part	Material	No.	Part	Material
1	Bolt	Stainless steel	30	Wave washer	65Mn
2	Stretching washer	Stainless steel	31	Ball bearing	
3	Washer	Stainless steel	32	Rotor	
4	Bolt	Stainless steel	33	Ball bearing	
5	Washer	Stainless steel	34	Screw	Stainless steel
6	Handle	Stainless steel	35	Washer	Stainless steel
7	Nut	Stainless steel	36	Connection part	HT200
8	Protector	NR	37	Mechanical seal	Carbon/Ceramic
9	Cable presser	Stainless steel	38	O-ring	NBR
10	Washer	Stainless steel	39	Oil chamber cover	HT200
11	Screw	Stainless steel	40	Screw	Stainless steel
12	Bolt	Stainless steel	41	Washer	Stainless steel
13	O-ring	NBR	42	O-ring	NBR
14	Screw	Stainless steel	43	Screw	Stainless steel
15	Flange	Stainless steel	44	Oil seal	
16	Cable		45	Impeller	HT200
17	Cable protector	CR	46	Nut	Stainless steel
18	Capacitor cover	HT200	47	Bolt	Stainless steel
19	Capacitor		48	Washer	Stainless steel
20	O-ring	NBR	49	Connector	ABS
21	Rubber washer	NBR	50	O-ring	NBR
22	Screw	CuZn40	51	Connector nut	HT200
23	Stretching washer	65Mn	52	Rubber washer	NBR
24	Washer	CuZn40	53	Pump body	HT200
25	Cable holder	NBR	54	Base plate	HT200
26	Motor cover	HT200	55	Washer	Stainless steel
27	Thermal protector		56	Screw	Stainless steel
28	O-ring	NBR	57	Float switch	
29	Stator				

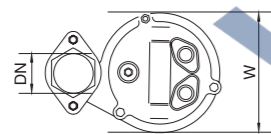
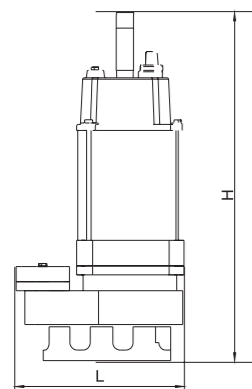
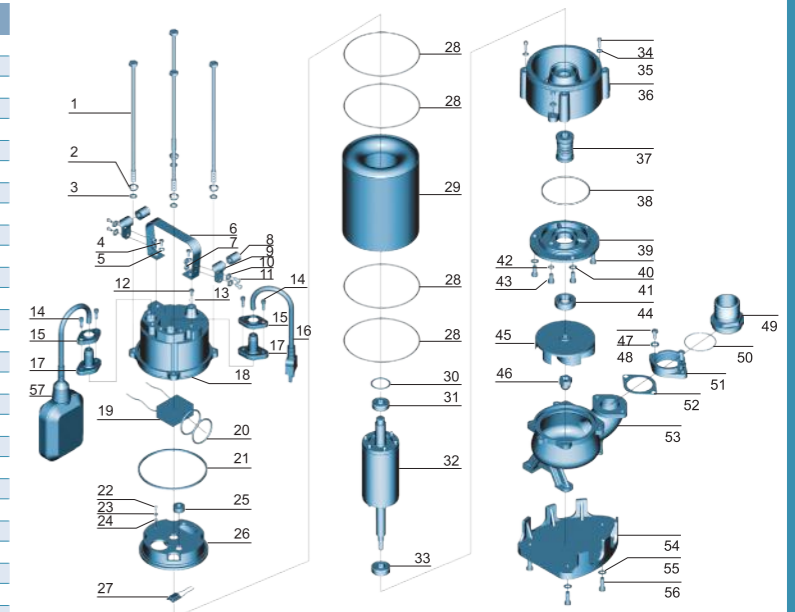

Dimension

Model	DN	L (mm)	W (mm)	H (mm)
XSP12-8.5/0.45I	2"	225	150	450
XSP18-12/0.75I	2"	226	159	500

Application

- Wastewater drainage in factories, construction sites and commercial facilities
- Drainage system in municipal sewage treatment plants
- Drainage station in residential quarters
- Municipal projects
- Methane pools and field irrigation in countryside

Pump

- Max. immersion depth: 5 m
- Max. liquid temperature: +40°C
- Liquid pH value: 4 – 10
- Liquid kinematic viscosity: $7 \times 10^{-7} \sim 23 \times 10^{-6} \text{ m}^2/\text{s}$
- Max. liquid density: $1.2 \times 10^3 \text{ kg/m}^3$

Motor

- Copper winding
- Built-in thermal protector
- Stainless steel welded shaft
- Insulation class: B
- Protection class: IP68

Identification Codes

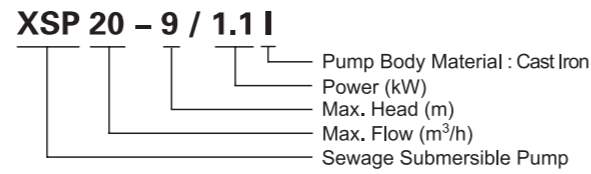

Hydraulic Performance Curves

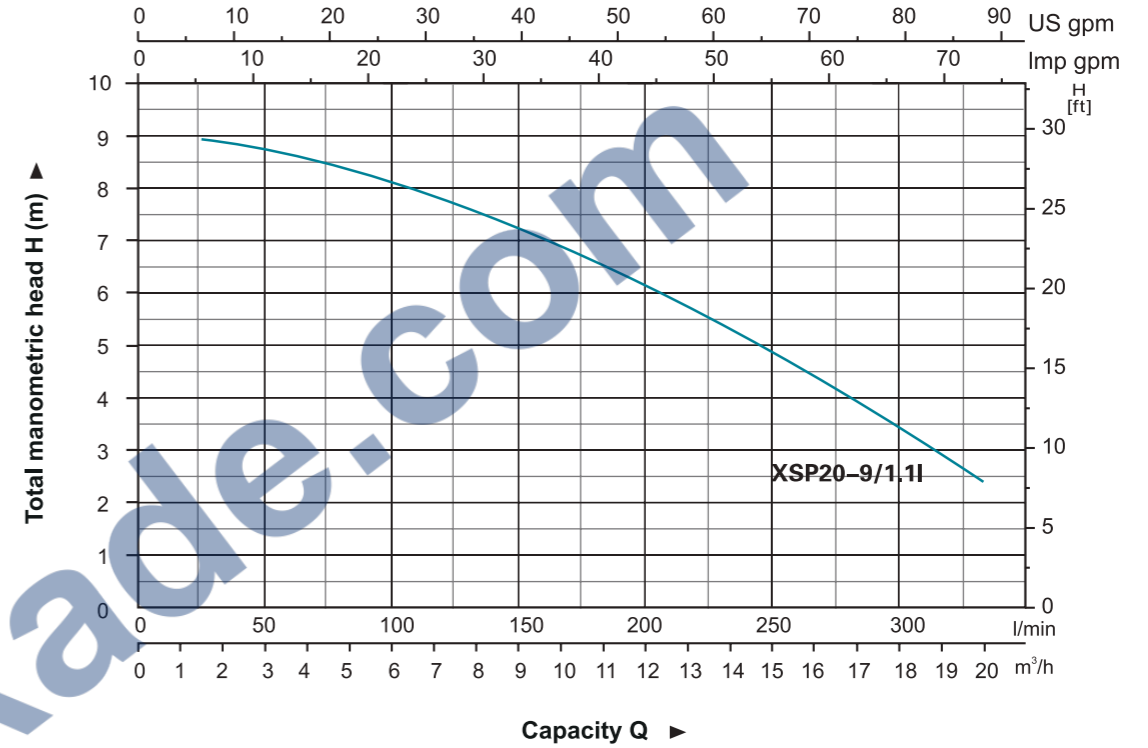

Technical Data

Model	Power		Outlet diameter (mm)	Voltage (V/Hz)	Max. flow (l/min)	Max. head (m)	Max. dia. of particle (mm)	GW (kgs)	Packing size (mm)	Quantity (PCS/20 TEU)
	(kW)	HP								
XSP20-9/1.1I	1.1	1.5	50	220/50	333	9	35	20.9	580x320x250	681

Materials Table

No.	Part	Material	No.	Part	Material
1	Bolt	Stainless steel	24	Washer	CuZn40
2	Stretching washer	Stainless steel	25	Cable holder	NBR
3	Washer	Stainless steel	26	Upper cover	HT200
4	Bolt	Stainless steel	27	Thermal protector	
5	Washer	Stainless steel	28	O-ring	NBR
6	Handle	Stainless steel	29	Stator	
7	Nut	Stainless steel	30	Wave washer	65Mn
8	Protector	NR	31	Ball bearing	
9	Cable presser	Stainless steel	32	Rotor	
10	Washer	Stainless steel	33	Ball bearing	
11	Screw	Stainless steel	34	Lower cover	HT200
12	Bolt	Stainless steel	35	Mechanical seal	Carbon/Ceramic
13	O-ring	NBR	36	Connector	ABS
14	Screw	Stainless steel	37	O-ring	NBR
15	Flange	Stainless steel	38	Pump body	HT200
16	Cable		39	Oil seal	
17	Cable protector	CR	40	Impeller	HT200
18	Capacitor cover	HT200	41	Nut	Stainless steel
19	Capacitor		42	Pump cover	Stainless steel
20	O-ring	NBR	43	Base plate	Stainless steel
21	Rubber washer	NBR	44	Washer	Stainless steel
22	Screw	CuZn40	45	Bolt	Stainless steel
23	Stretching washer	65Mn	46	Float switch	

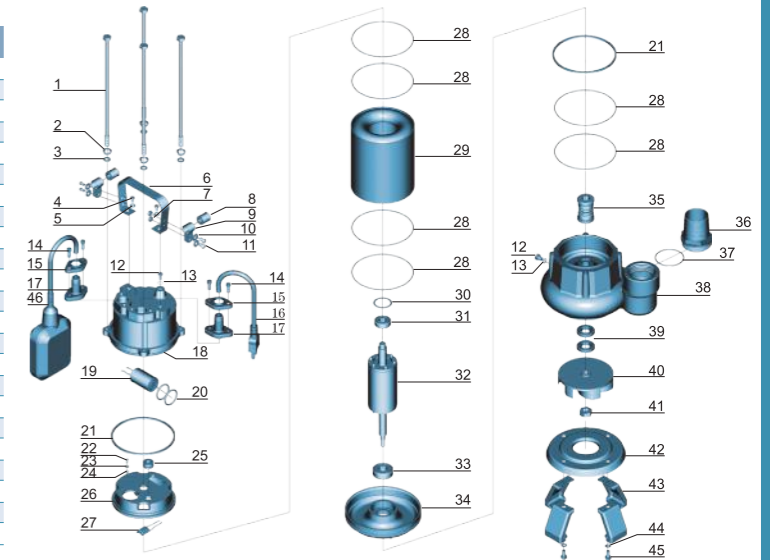

Dimension

Model	DN	L (mm)	W (mm)	H (mm)
XSP20-9/1.1I	2"	280	200	530

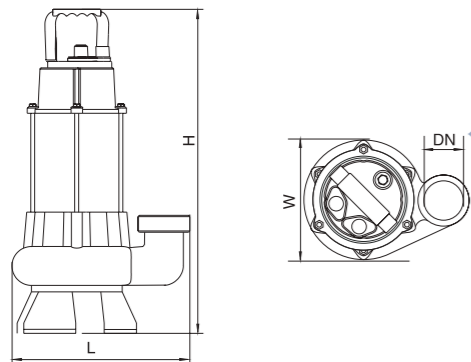

Application

- Wastewater drainage in factories, construction sites and commercial facilities
- Drainage system in municipal sewage treatment plants
- Drainage station in residential quarters
- Municipal projects
- Methane pools and field irrigation in countryside

Pump

- Max. immersion depth: 5 m
- Max. liquid temperature: +40°C
- Liquid pH value: 4 – 10
- Liquid kinematic viscosity: $7 \times 10^{-7} \sim 23 \times 10^{-6} \text{ m}^2/\text{s}$
- Max. liquid density: $1.2 \times 10^3 \text{ kg/m}^3$

Motor

- Copper winding
- Built-in thermal protector
- Stainless steel welded shaft
- Insulation class: B
- Protection class: IP68

Identification Codes

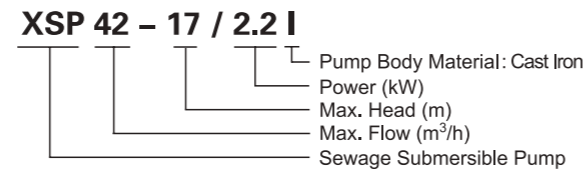

Hydraulic Performance Curves

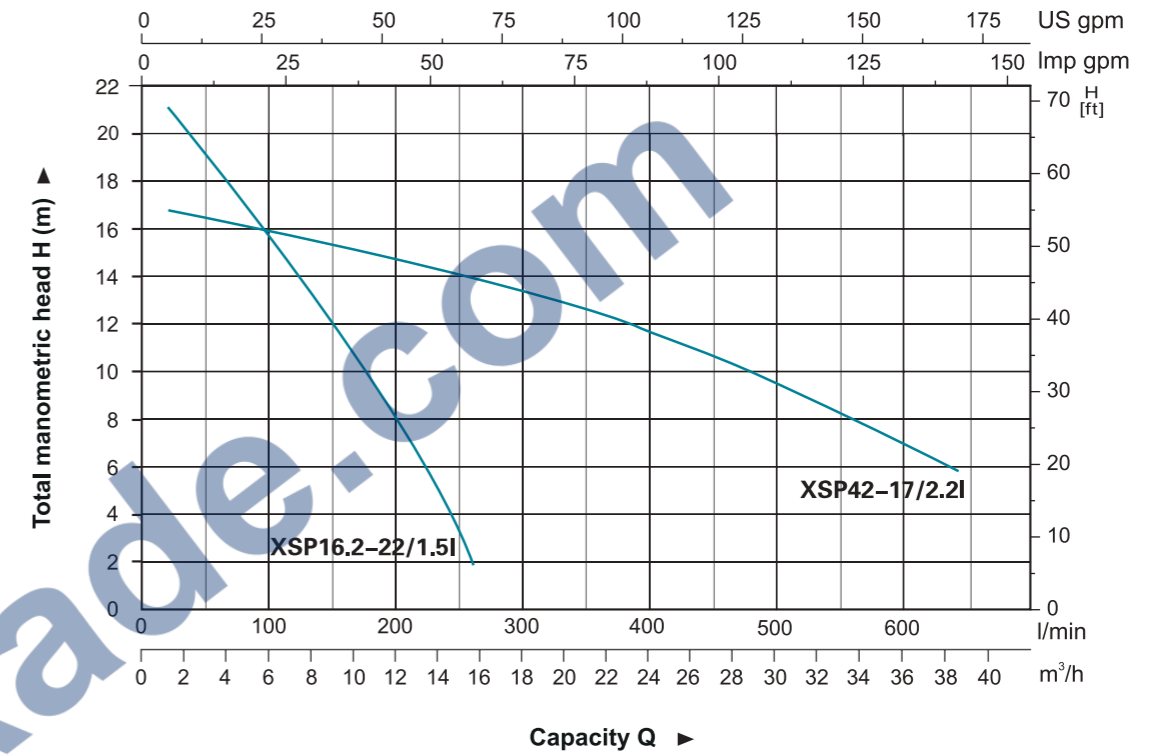

Technical Data

Model	Power		Outlet diameter (mm)	Voltage (V/Hz)	Max.flow (l/min)	Max.head (m)	Max.dia. of particle (mm)	GW (kgs)	Packing size (mm)	Quantity (PCS/20 TEU)
	(kW)	HP								
XSP16.2-22/1.5I	1.5	2.0	40	220/50	270	22	10	27.6	585x350x245	540
XSP42-17/2.2I	2.2	3.0	75	220/50	700	17	20	29.7	585x350x245	540

Materials Table

No.	Part	Material	No.	Part	Material
1	Bolt	11	30	Undulated washer	1566
2	Stretching washer	11	31	Ball bearing	
3	Washer	11	32	Rotor	
4	Bolt	11	33	Ball bearing	
5	Washer	11	34	Screw	11
6	Handle	11	35	Washer	11
7	Nut	11	36	Connection part	No35B
8	Protector	NR	37	Mechanical seal	Alumina/Graphite
9	Cable presser	11	38	O'ring	NBR
10	Washer	11	39	Oil chamber cover	No35B
11	Screw	11	40	Screw	11
12	Bolt	11	41	Washer	11
13	O'ring	NBR	42	O'ring	NBR
14	Screw	11	43	Screw	11
15	Flange	11	44	Oil seal	
16	Cable		45	Impeller	No35B
17	Cable protector	CR	46	Nut	11
18	Capacitor cover	No35B	47	Bolt	11
19	Capacitor		48	Washer	11
20	O'ring	NBR	49	Out-let connector	ABS
21	Rubber washer	NBR	50	O'ring	NBR
22	Screw	CuZn40	51	Connection nut	No35B
23	Stretching washer	1566	52	Rubber washer	NBR
24	Washer	CuZn40	53	Pump body	No35B
25	Line protector	NBR	54	Base plate	No35B
26	Motor cover	No35B	55	Washer	11
27	Thermal protector		56	Screw	11
28	O'ring	NBR	57	Key	4
29	Motor stator	11	58	Float switch	

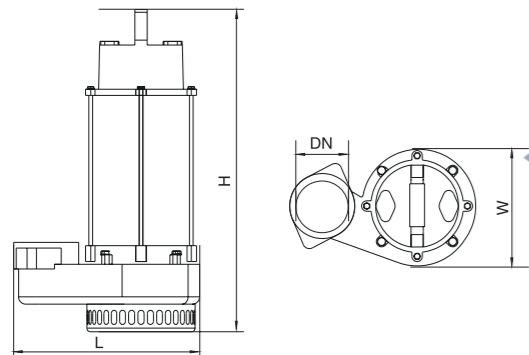
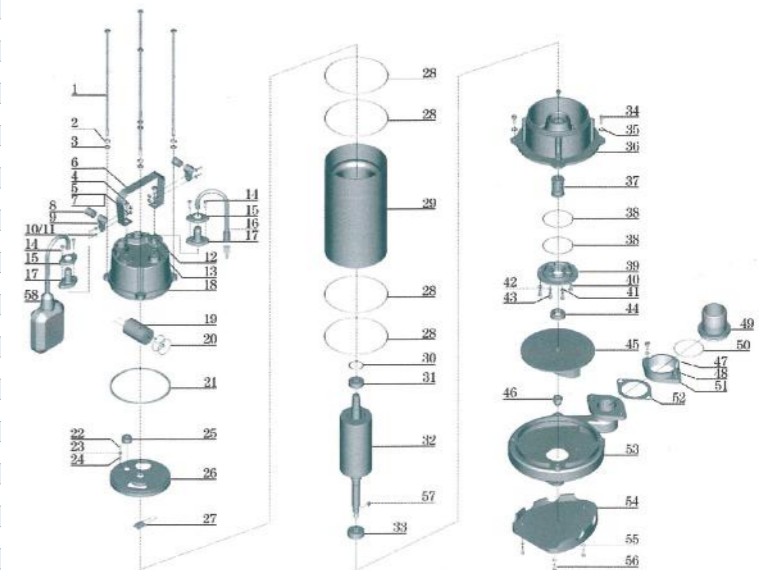

Dimension

Model	DN	L (mm)	W (mm)	H (mm)
XSP16.2-22/1.5I	2"	308	198	530
XSP42-17/2.2I	2 1/2"	302	190	535

Application

- Wastewater drainage in factories, construction sites and commercial facilities
- Drainage system in municipal sewage treatment plants
- Drainage station in residential quarters
- Municipal projects
- Methane pools and field irrigation in countryside

Pump

- Max. immersion depth: 5 m
- Max. liquid temperature: +40°C
- Liquid pH value: 4 – 10
- Liquid kinematic viscosity: $7 \times 10^{-7} \sim 23 \times 10^{-6} \text{ m}^2/\text{s}$
- Max. liquid density: $1.2 \times 10^3 \text{ kg/m}^3$

Motor

- Copper winding
- Built-in thermal protector
- Stainless steel welded shaft
- Insulation class: B
- Protection class: IP68

Identification Codes

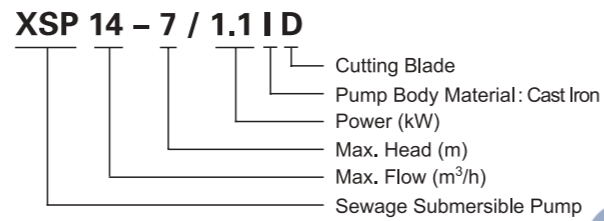

Hydraulic Performance Curves

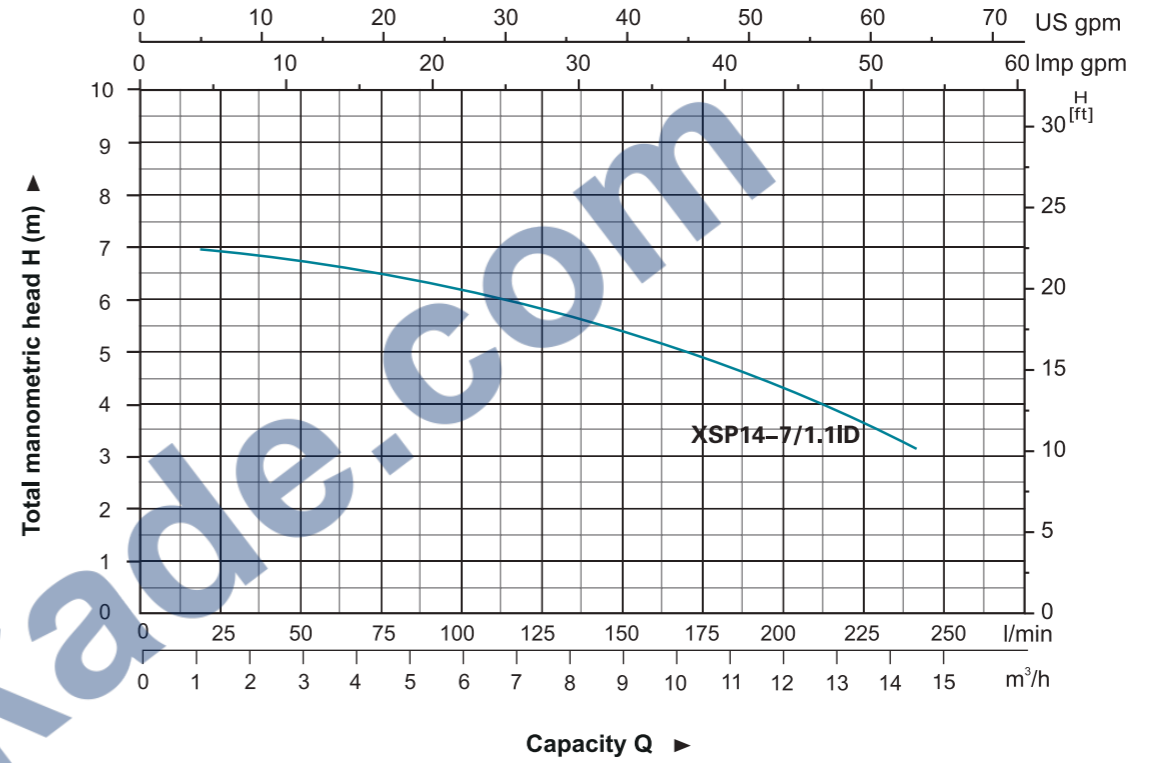

Technical Data

Model	Power		Outlet diameter (mm)	Voltage (V/Hz)	Max.flow (l/min)	Max.head (m)	Max.dia. of particle (mm)	GW (kgs)	Packing size (mm)	Quantity (PCS/20 TEU)
	(kW)	HP								
XSP14-7/1.1ID	1.1	1.5	50	220/50	233	7	22.5	24	530x295x245	765

Materials Table

No.	Part	Material	No.	Part	Material
1	Bolt	Stainless steel	26	Upper cover	HT200
2	Stretching washer	Stainless steel	27	Thermal protector	
3	Washer	Stainless steel	28	O-ring	NBR
4	Bolt	Stainless steel	29	Stator	
5	Washer	Stainless steel	30	Wave washer	65Mn
6	Handle	Stainless steel	31	Ball bearing	
7	Nut	Stainless steel	32	Rotor	
8	Protector	NR	33	Key	Steel
9	Cable presser	Stainless steel	34	Ball bearing	
10	Washer	Stainless steel	35	Lower cover	HT200
11	Screw	Stainless steel	36	Mechanical seal	Carbon/Ceramic
12	Bolt	Stainless steel	37	Pump body	HT200
13	O-ring	NBR	38	Oil seal	
14	Screw	Stainless steel	39	Impeller	HT200
15	Flange	Stainless steel	40	Shredding ring	40Cr
16	Cable		41	Washer	Stainless steel
17	Cable protector	CR	42	Screw	Stainless steel
18	Capacitor cover	HT200	43	Radial cutter	40Cr
19	Capacitor		44	Washer	40Cr
20	O-ring	NBR	45	Screw	Stainless steel
21	Rubber washer	NBR	46	Float switch	
22	Screw	CuZn40	47	O-ring	NBR
23	Stretching washer	65Mn	48	Connection nut	ABS
24	Washer	CuZn40	49	Connector	ABS
25	Cable holder	NBR			

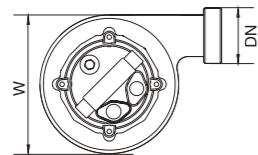
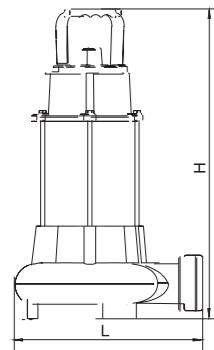
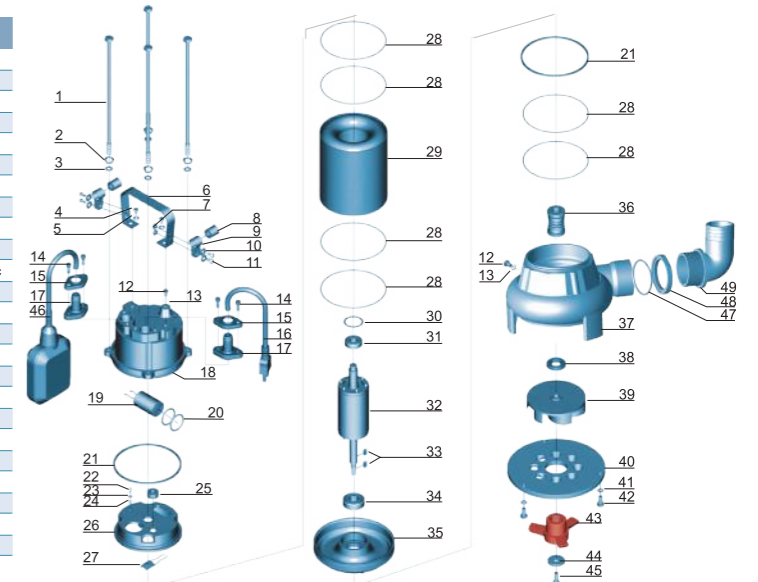

Dimension

Model	DN	L (mm)	W (mm)	H (mm)
XSP14-7/1.1ID	2"	255	202	478

Application

- Wastewater drainage in factories, construction sites and commercial facilities
- Drainage system in municipal sewage treatment plants
- Drainage station in residential quarters
- Municipal projects
- Methane pools and field irrigation in countryside

Pump

- Max. immersion depth: 5 m
- Max. liquid temperature: +40°C
- Liquid pH value: 4 – 10
- Liquid kinematic viscosity: $7 \times 10^{-7} \sim 23 \times 10^{-6} \text{ m}^2/\text{s}$
- Max. liquid density: $1.2 \times 10^3 \text{ kg/m}^3$

Motor

- Copper winding
- Built-in thermal protector
- Stainless steel welded shaft
- Insulation class: B
- Protection class: IP68

Identificati

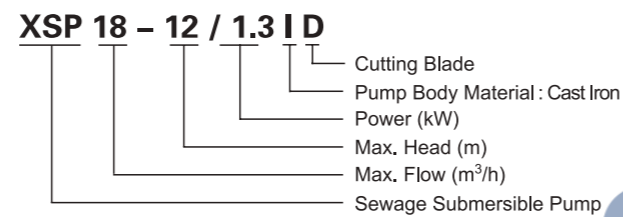

Hydraulic Performance Curves

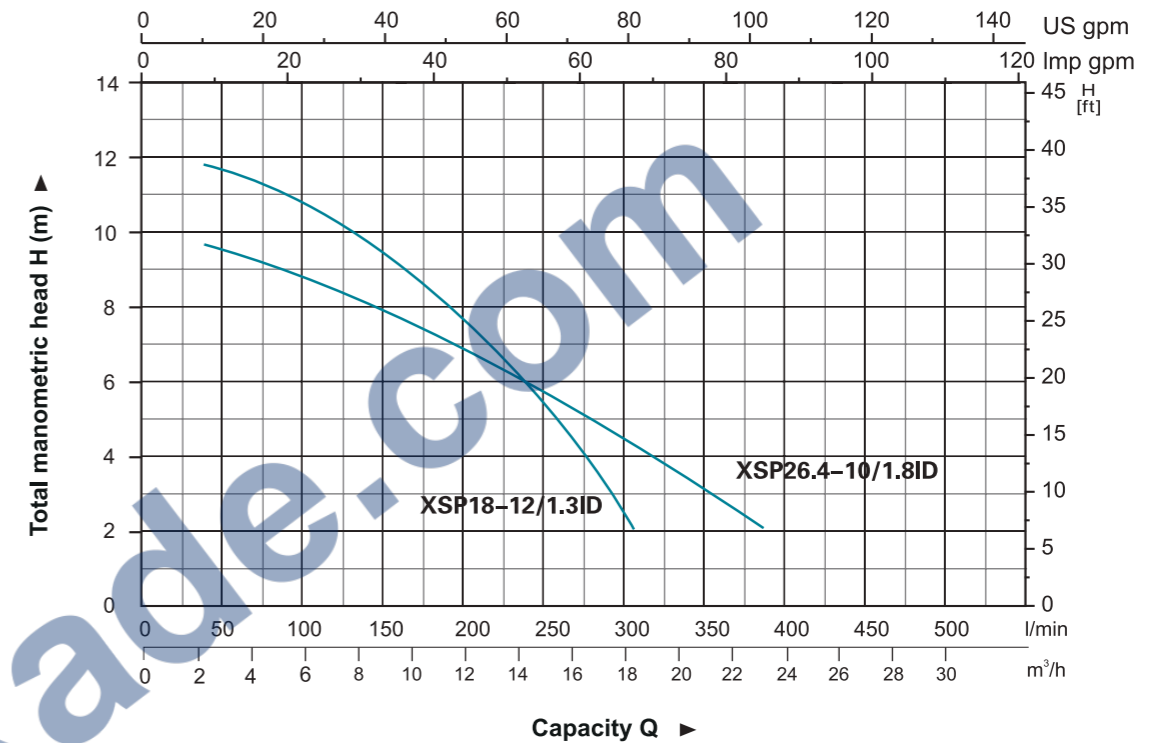

Technical Data

Model	Power		Outlet diameter (mm)	Voltage (V/Hz)	Max. flow (l/min)	Max. head (m)	GW (kgs)	Packing size (mm)	Quantity (PCS/20' TEU)
	(kW)	HP							
XSP18-12/1.3ID	1.3	1.75	50	220/50	300	12	22.8	570x310x245	675
XSP26.4-10/1.8ID	1.8	2.4	75	220/50	440	10	30	585x350x245	540

Materials Table

No.	Part	Material	No.	Part	Material
1	Bolt	Stainless steel	30	Undulated washer	65Mn
2	Stretching washer	Stainless steel	31	Ball bearing	
3	Washer	Stainless steel	32	Rotor	
4	Bolt	Stainless steel	33	Ball bearing	
5	Washer	Stainless steel	34	Screw	Stainless steel
6	Handle	Stainless steel	35	Washer	Stainless steel
7	Nut	Stainless steel	36	Connection part	HT200
8	Protector	NR	37	Mechanical seal	Carbon/Ceramic
9	Cable presser	Stainless steel	38	O-ring	NBR
10	Washer	Stainless steel	39	Oil chamber cover	HT200
11	Screw	Stainless steel	40	Screw	Stainless steel
12	Bolt	Stainless steel	41	Washer	Stainless steel
13	O-ring	NBR	42	O-ring	NBR
14	Screw	Stainless steel	43	Screw	Stainless steel
15	Flange	Stainless steel	44	Oil seal	
16	Cable		45	Pump body	HT200
17	Cable Protector	CR	46	Impeller	HT200
18	Capacitor cover	HT200	47	Shredding ring	40Cr
19	Capacitor		48	Washer	Stainless steel
20	O-ring	NBR	49	Bolt	Stainless steel
21	Rubber washer	NBR	50	Radial cutter	40Cr
22	Screw	CuZn40	51	Washer	40Cr
23	Stretching washer	65Mn	52	Screw	Stainless steel
24	Washer	CuZn40	53	Key	Steel
25	Line protector	NBR	54	Float switch	
26	Motor cover	HT200	55	O-ring	NBR
27	Thermal protector		56	Connection nut	ABS
28	O-ring	NBR	57	Out-let connector	ABS
29	Motor stator	Stainless steel			

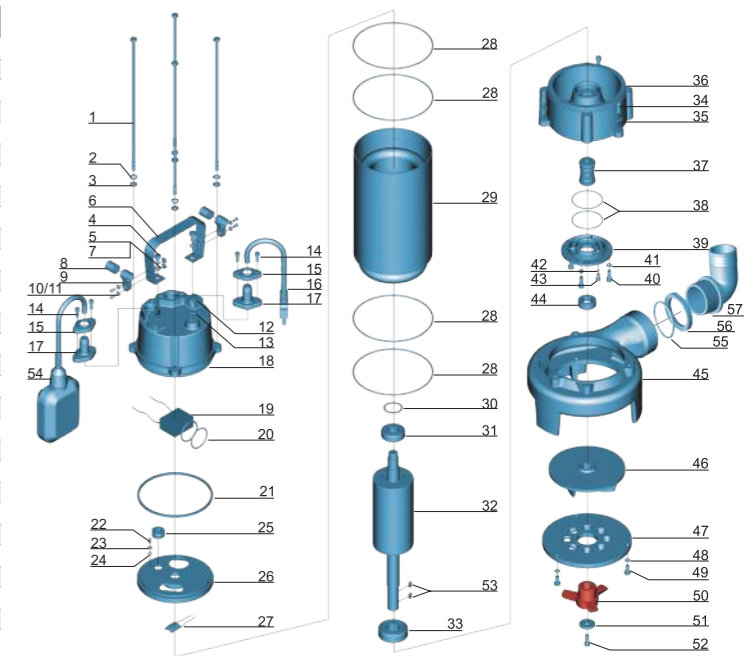

Dimension

Model	DN	L (mm)	W (mm)	H (mm)
XSP18-12/1.3ID	2"	252	191	510
XSP26.4-10/1.8ID	2 1/2"	290	196	520

