



Application

- Clean water or other liquids similar to water in physical and chemical properties
- Small living water supply, Automatic water sprinkler system, Garden irrigation, Temporary water taking etc.

Pump

- Low noise (55dB) and Less vibration
- Small and exquisite, easy to install and carry
- Auto-Start/Stop (with float switch type)
- Engineering plastic material have no pollution to water

Motor

- Insulation class: F
- Protection class: IPX8

Identification Codes

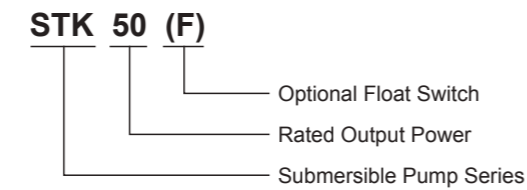

Hydraulic Performance Curves

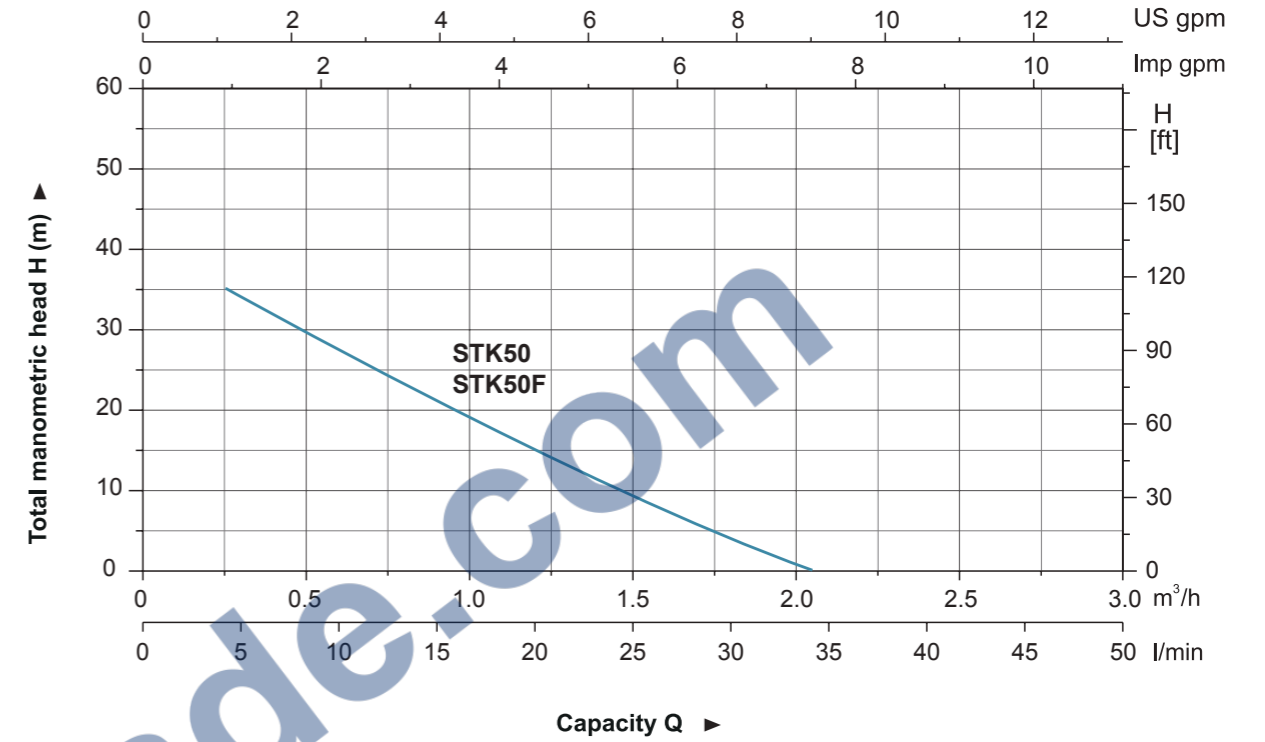

Materials Table

No.	Part	Material	No.	Part	Material
1	Handle	PP-GF30	14	Rotor	
2	Top cap	PP-GF30	15	Stator	
3	Capacitance		16	Framework	
4	Capacitor clamp	PC/ABC	17	Impeller	HPb59-1
5	Cable		18	Pump body subassembly	ADC12
6	Float switch				
7	Cable jacket	EPDM			
8	Cable clamp	PA6-GF25			
9	Cable plate	PA6-GF25			
10	Plastic support	PP-GF30			
11	Pedestal	PP-GF30			
12	Bearing cover	ADC12			
13	Bearing				

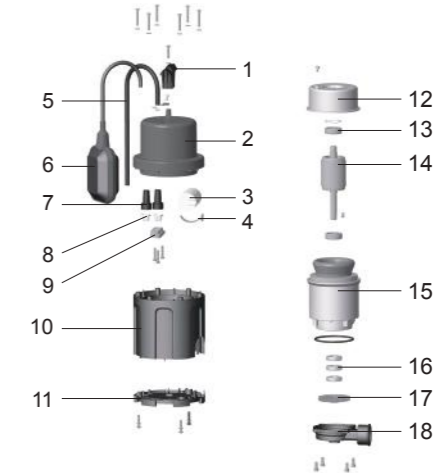

Technical Data

MODEL	Voltage (V/Hz)	Power		Max.flow		Max.head (m)	Max.immersion Depth (m)	Outlet
		KW	HP	L/min	m³/h			
STK50(F)	220-240	0.37	0.5	40	2.4	35	10	1"

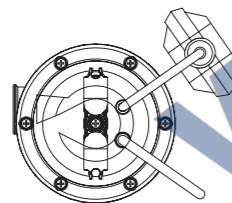
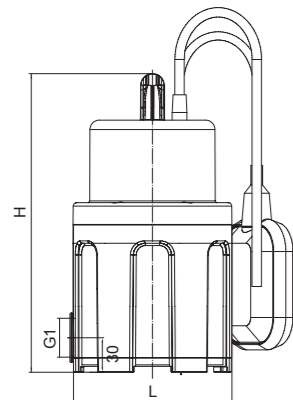

Dimension

MODEL	DN	L (mm)	H (mm)
STK50	1"	135	255
STK50(F)	1"	135	255

Package Information

Model	GW (Kgs)	L (mm)	W (mm)	H (mm)	Quantity (PCS/20 TEU)
STK50	3.95	150	150	320	3024
STK50(F)	4.12	150	150	270	3332

