



Application

- Water supply: Pressure boosting for main pipes and high-rise buildings
- Industrial pressure boosting: Water system, cleaning system, high pressure washing system and firefighting system
- Pressure boosting for pressure tank, sprinkling irrigation and trichling irrigation
- Air conditioner, cooling system and industrial cleaning

Features

- Applicable for a wide scope of different temperatures, flow rates and pressure ranges
- Water inlet and outlet can be rotated for proper assembly in accordance with installation requirement
- Easy installation and maintenance
- Advanced hydraulic model design, featuring stable operation and high efficiency
- Cast iron water inlet and outlet with special anti-rust treatment
- High-strength engineering plastic flow passage components
- Reliable stainless steel welded shaft

Working Conditions

- Liquid temperature: +5°C ~ 60°C
- Maximum ambient temperature: +40°C
- Maximum pressure: 15 bar
- Altitude: up to 1000 m

Identification Codes

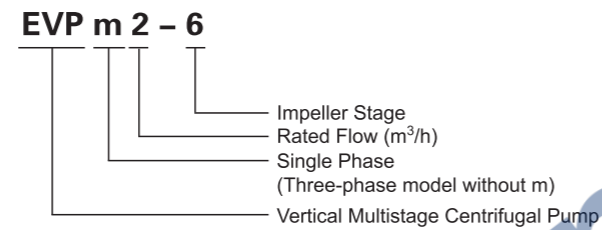

Model Selection Instructions

- Voltage and frequency: Single-phase 220-240V/50Hz;
Three-phase 380-415V/50Hz.
- Please choose the pump with appropriate flow rate and head to meet your actual demand.

Hydraulic Performance Curves

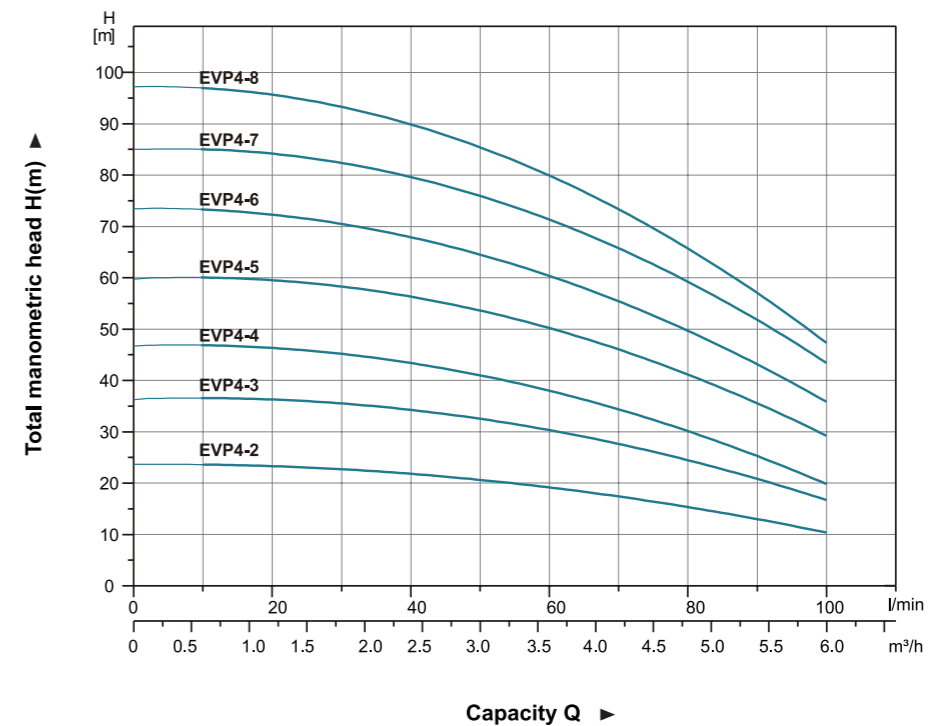
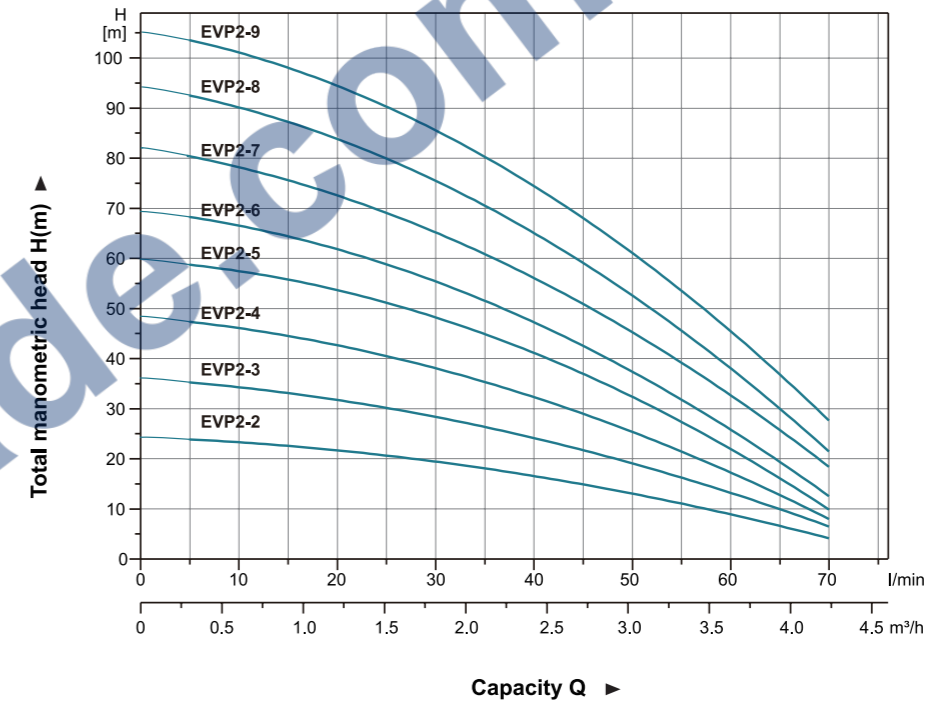

Materials Table

No.	Part	Material
1	Fan cover	08F
2	Fan	PP
3	End plate	Cast Iron
4	Bearing	
5	Stator	
6	Rotor	
7	Gasket	Rubber
8	Flange	Cast Iron
9	Motor Bracket	Aluminum
10	Machanical seal	
11	Pump Barrel	AISI 304
12	Impeller	Plastic
13	Diffuser	Plastic
14	Last Diffuser	Plastic
15	Capactor box	Plastic

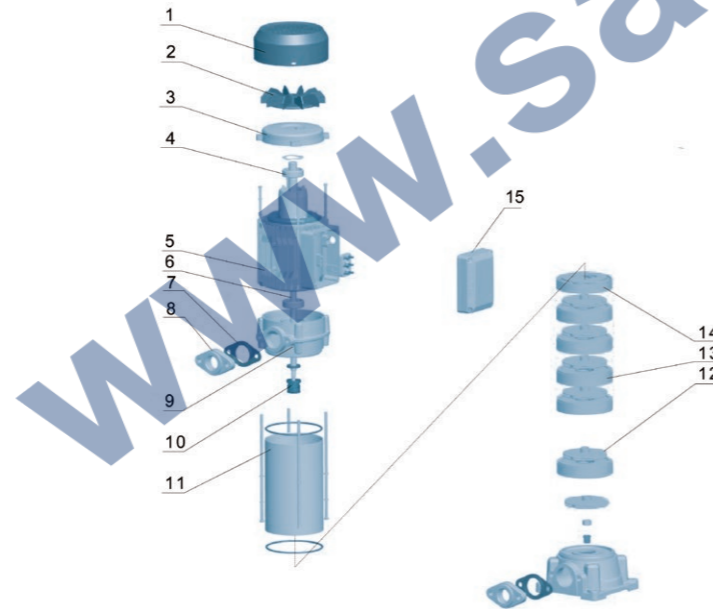

Hydraulic Performance Curves

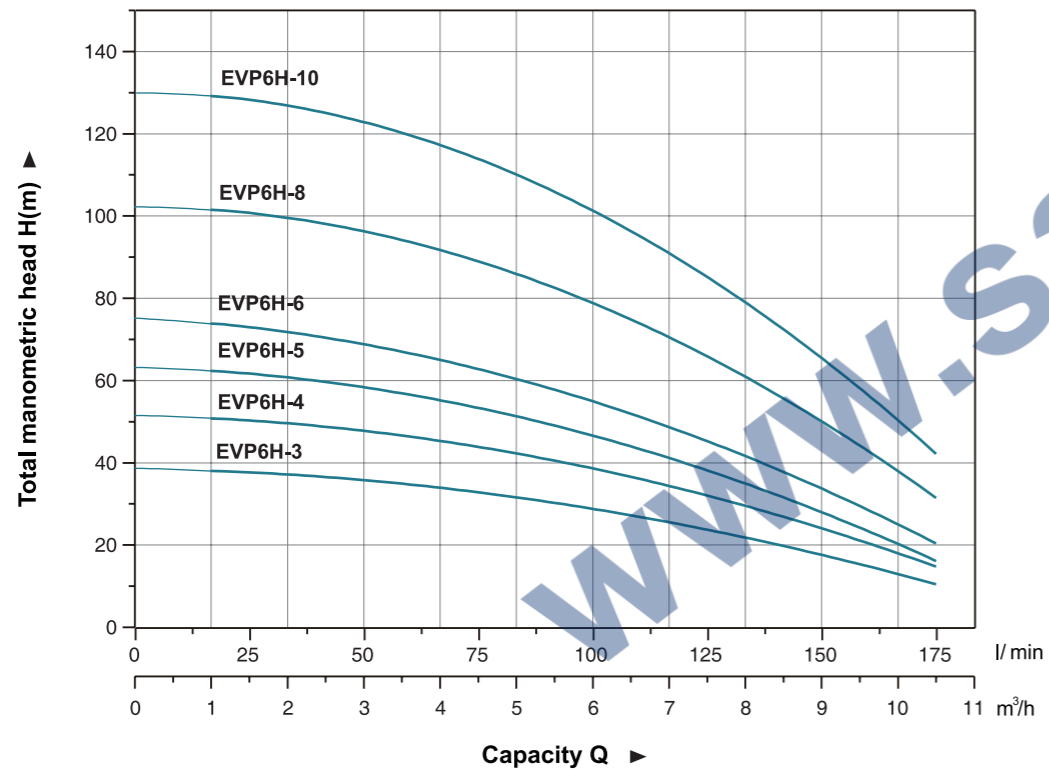
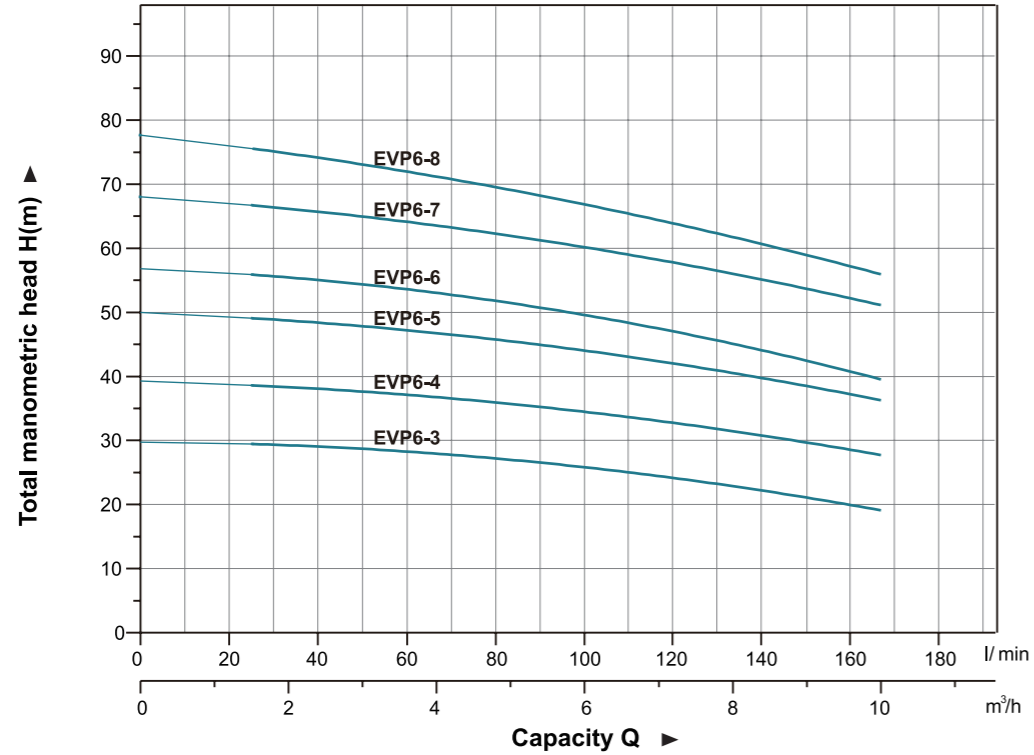

Hydraulic Performance Curves

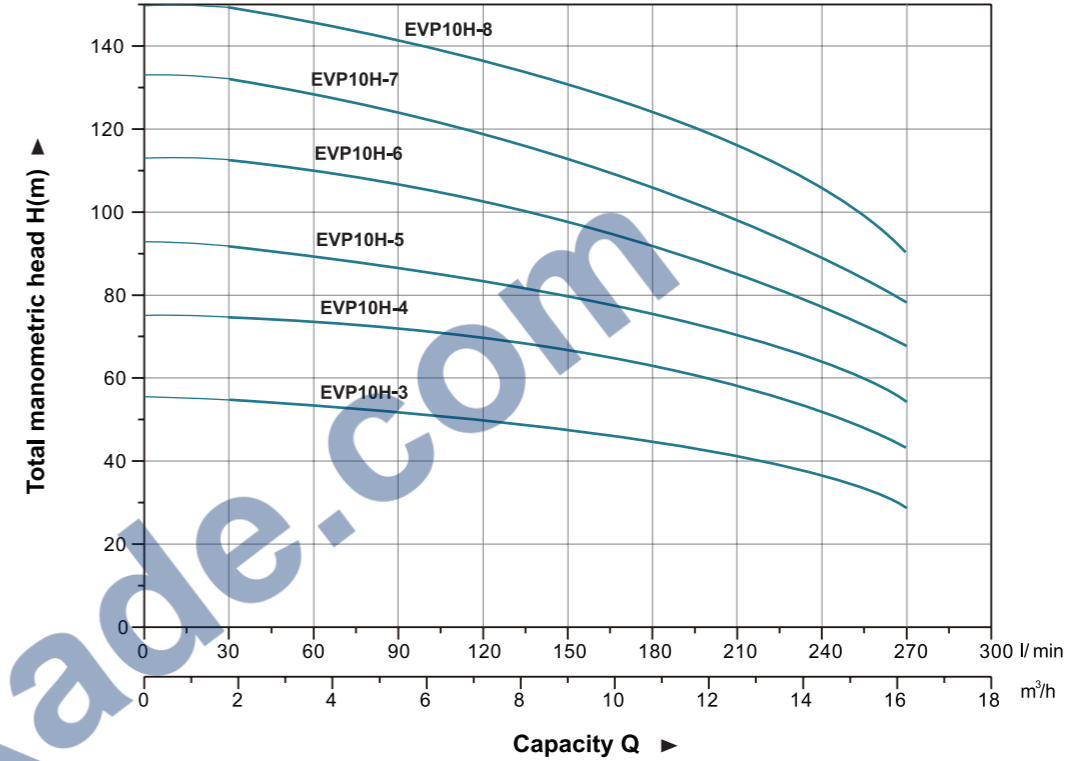

Technical Data

Model		Power (P2)		Q (m³/h)		0	1	2	3	4
Single-phase	Three-phase	kW	HP	Q (l/min)	0	16.7	33.3	50	66.7	
EVPm2-2	EVP2-2	0.37	0.5	H (m)	24	23	18	13	6	
EVPm2-3	EVP2-3	0.55	0.75		36	33	26	20	9	
EVPm2-4	EVP2-4	0.75	1.0		48	45	35	26	11	
EVPm2-5	EVP2-5	1.0	1.3		59	57	44	33	15	
EVPm2-6	EVP2-6	1.0	1.3		69	65	52	37	18	
EVPm2-7	EVP2-7	1.1	1.5		82	75	62	45	25	
EVPm2-8	EVP2-8	1.5	2.0		94	87	72	52	28	
EVPm2-9	EVP2-9	1.5	2.0		105	98	82	60	35	

Model		Power (P2)		Q (m³/h)		0	1	2	3	4	5	6
Single-phase	Three-phase	kW	HP	Q (l/min)	0	16.7	33.3	50	66.7	83.3	100	
EVPm4-2	EVP4-2	0.55	0.75	H (m)	24	23	22	21	18	15	10	
EVPm4-3	EVP4-3	0.75	1.0		37	36	34	33	29	24	16	
EVPm4-4	EVP4-4	1.0	1.3		47	46	45	41	36	28	20	
EVPm4-5	EVP4-5	1.5	2.0		61	58	57	55	48	39	29	
EVPm4-6	EVP4-6	1.5	2.0		74	72	69	66	57	47	36	
—	EVP4-7	2.2	3.0		86	83	81	77	68	57	43	
—	EVP4-8	2.2	3.0		98	95	92	86	76	63	47	

Technical Data

Model		Power (P2)		Q (m ³ /h)	0	1	2	3	4	5	6	7	8	9	10
Single-phase	Three-phase	kW	HP	Q (l/min)	0	16.7	33.3	50	66.7	83.3	100	116.7	133.3	150	166.7
EVPm6-3	EVP6-3	1.1	1.5	H (m)	30	29.5	29	28.5	28	27	26	24.5	23	21	19
EVPm6-4	EVP6-4	1.5	2.0		40	38.5	37.5	37.3	37	36	34	33.5	32	30	27
—	EVP6-5	2.2	3.0		50	49	48.5	48.3	48	45	43	42	41	39	36
—	EVP6-6	2.2	3.0		58	56	54	53.5	53	52	51	48	45	41	40
—	EVP6-7	3.0	4.0		68	67	66.5	65	63.5	62	60	58	56	54	51
—	EVP6-8	3.0	4.0		78	75	73	72	71	70	68	65	62	59	55

Model		Power (P2)		Q (m ³ /h)	0	1	2	3	4.5	6	7.5	9	10.5
Single-phase	Three-phase	kW	HP	Q (l/min)	0	16.7	33.3	50	70	100	125	150	175
EVPm6H-3	EVP6H-3	1.1	1.5	H (m)	39	38	37	35	33	29	24	18	10
EVPm6H-4	EVP6H-4	1.5	2		52	51	49	47	44	39	32	25	14
EVPm6H-5	EVP6H-5	1.8	2.5		64	62	60	58	54	47	38	28	16
—	EVP6H-6	2.2	3		76	74	71	68	63	56	45	34	20
—	EVP6H-8	3.0	4		103	100	97	95	90	80	66	50	31
—	EVP6H-10	4.0	5.5		130	127	124	121	114	103	86	66	41

Model		Power (P2)		Q (m ³ /h)	0	2	4	6	8	10	12	14	16
Three-phase	kW	HP	Q (l/min)	0	33.3	66.7	100	133.6	167	200.4	233.8	267.2	
EVP10H-3	3.0	4.0	H (m)	56	55	54	52	49	46	42	39	29	
EVP10H-4	4.0	5.4		75	74	72	70	67	64	60	53	43	
EVP10H-5	5.5	7.5		93	91	87	84	81	77	72	64	55	
EVP10H-6	5.5	7.5		113	110	107	104	100	96	87	78	68	
EVP10H-7	7.5	10		132	128	124	120	116	112	103	93	80	
EVP10H-8	7.5	10		150	147	143	139	134	127	120	108	92	

Dimension

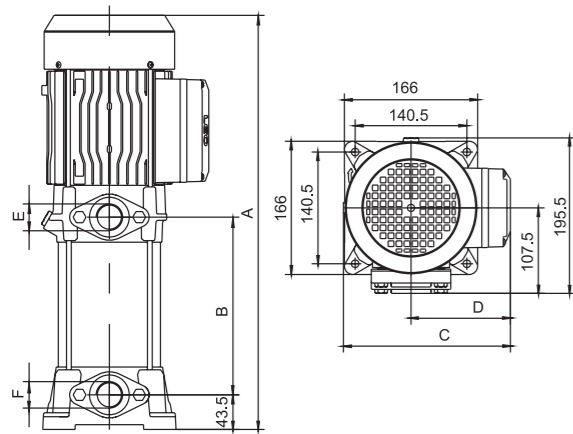

Model		Power (P2)	A	B	C	D	E	F
Single-phase	Three-phase	kW						
EVPm2-2	EVP2-2	0.37	382	120	193	110	G1	G1
EVPm2-3	EVP2-3	0.55	406	144	193	110	G1	G1
EVPm2-4	EVP2-4	0.75	430	168	193	110	G1	G1
EVPm2-5	EVP2-5	1.0	454	192	193	110	G1	G1
EVPm2-6	EVP2-6	1.0	478	216	193	110	G1	G1
EVPm2-7	EVP2-7	1.1	545	247.5	210	125	G1	G1
EVPm2-8	EVP2-8	1.5	569	271.5	210	125	G1	G1
EVPm2-9	EVP2-9	1.5	593	295.5	210	125	G1	G1

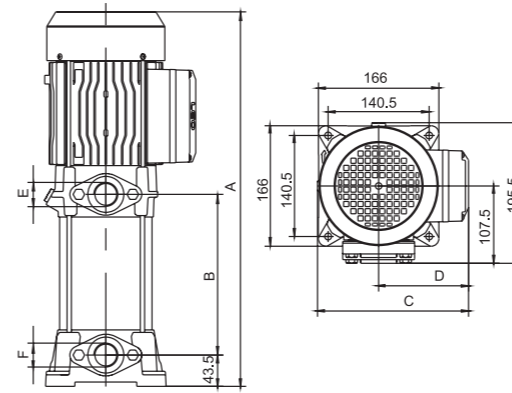

Model		Power (P2)	A	B	C	D	E	F
Single-phase	Three-phase	kW						
EVPm4-2	EVP4-2	0.55	382	120	193	110	G1	G1
EVPm4-3	EVP4-3	0.75	406	144	193	110	G1	G1
EVPm4-4	EVP4-4	1.0	430	168	193	110	G1	G1
EVPm4-5	EVP4-5	1.5	497	199.5	210	125	G1	G1
EVPm4-6	EVP4-6	1.5	521	223.5	210	125	G1	G1
—	EVP4-7	2.2	545	247.5	210	125	G1	G1
—	EVP4-8	2.2	569	271.5	210	125	G1	G1

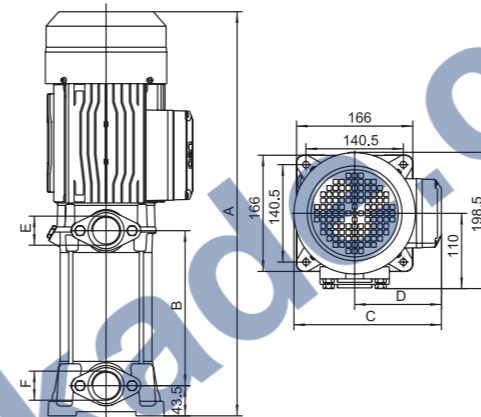

Model		Power (P2)	A	B	C	D	E	F
Single-phase	Three-phase	kW						
EVPm6-3	EVP6-3	1.1	487	190	210	125	G1½	G1½
EVPm6-4	EVP6-4	1.5	524	227	210	125	G1½	G1½
—	EVP6-5	2.2	561	264	210	125	G1½	G1½
—	EVP6-6	2.2	598	301	210	125	G1½	G1½
—	EVP6-7	3.0	685	338	221	134	G1½	G1½
—	EVP6-8	3.0	722	375	221	134	G1½	G1½

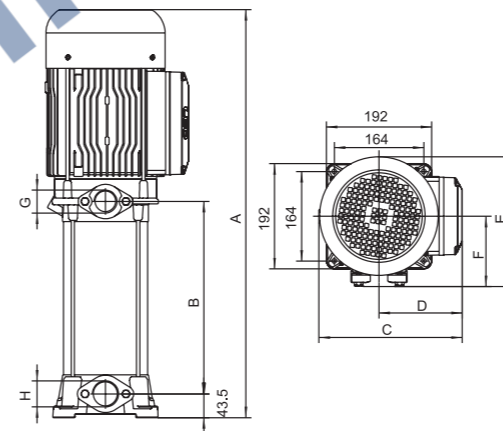

Model	Power (P2)	A	B	C	D	E	F	G	H
Three-phase	kW								
EVP10H-3	3.0	554.5	187	240	141	227.5	127.5	G1½	G1½
EVP10H-4	4.0	577.5	220	240	141	227.5	127.5	G1½	G1½
EVP10H-5	5.5	647	253	262	152	237.5	128.5	G1½	G1½
EVP10H-6	5.5	680	286	262	152	237.5	128.5	G1½	G1½
EVP10H-7	7.5	713	319	262	152	237.5	128.5	G1½	G1½
EVP10H-8	7.5	746	352	262	152	237.5	128.5	G1½	G1½

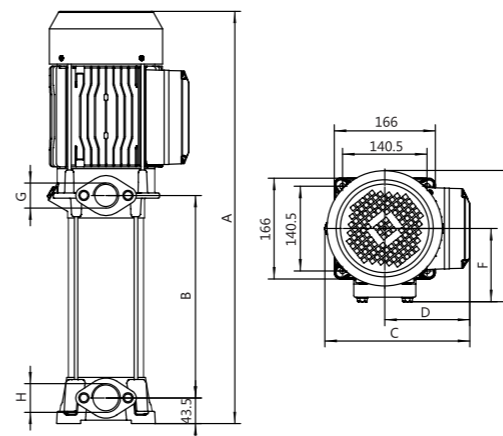

Model		P2(kW)	A	B	C	D	E	F	G	H
Single-phase	Three-phase									
EVPm6H-3	EVP6H-3	1.1	457	158.5	210	125	202	114.5	G1½	G1½
EVPm6H-4	EVP6H-4	1.5	483.5	185	210	125	202	114.5	G1½	G1½
EVPm6H-5	EVP6H-5	1.8	510	211.5	210	125	202	114.5	G1½	G1½
—	EVP6H-6	2.2	536.5	238	210	125	202	114.5	G1½	G1½
—	EVP6H-8	3.0	655	297.5	240	141	218	121.5	G1½	G1½
—	EVP6H-10	4.0	708	350.5	240	141	218	121.5	G1½	G1½