

Application

- Can be used to transfer clean water or other liquids similar to water in physical and chemical properties
- Suitable for small living water supply, automatic water sprinkler system, small air conditioner system or supporting equipment etc.

Pump

- Special anti-rust treatment for cast iron pump body and support
- Brass impeller
- AISI 304 shaft
- Max. liquid temperature: +60°C
- Max. suction: +8 m

Motor

- C&U bearing
- Motor with copper winding
- Built-in thermal protector for single phase motor
- Insulation class: F
- Protection class: IPX4
- Max. ambient temperature: +40°C

Identification Codes

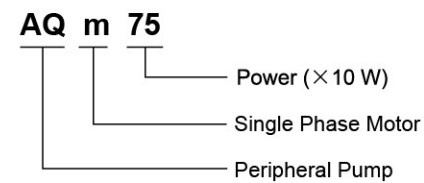

Hydraulic Performance Curves

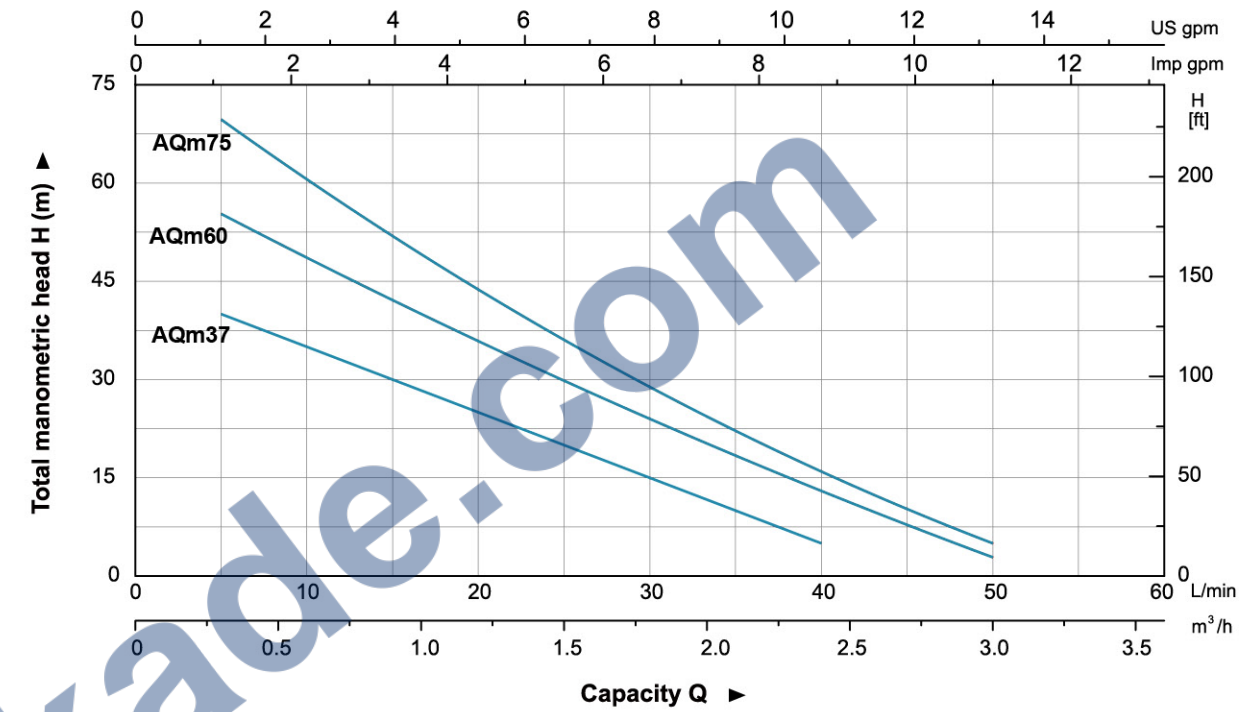

Materials Table

No.	Part	Material
1	Pump body	HT200
2	Impeller	Brass
3	O-ring	NBR
4	Mechanical seal	Carbon/Ceramic
5	Support	HT200
6	Bearing	
7	Rotor	
8	Fan cover	08F
9	Fan	PP
10	Rear cover	ZL102
11	Capacitor	
12	Terminal box	ABS
13	Terminal board	PC
14	Stator	
15	Filling plug	HPb59-1

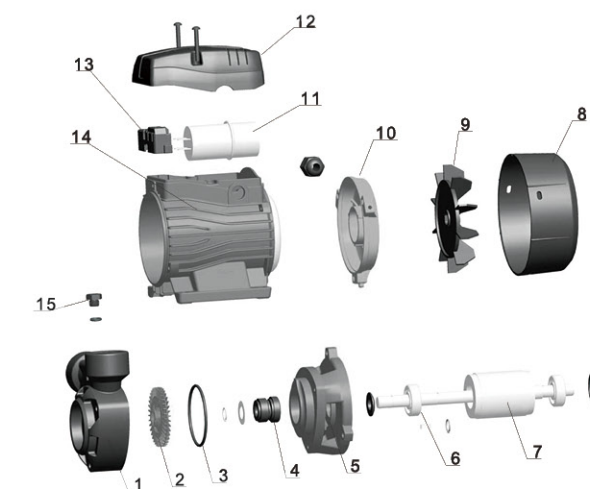

Technical Data

Model	POWER		Q (m³/h)	H (m)										
	kW	HP		0	0.3	0.6	0.9	1.2	1.5	1.8	2.1	2.4	2.7	
AQm37	0.37	0.5	40	35	30	25	20	15	10	5	2	-		
AQm60	0.6	0.8	60	55	50	40	35	30	25	20	10	5		
AQm75	0.75	1	75	70	60	50	45	35	28	22	15	5		

Dimension

Model	DN1	DN2	L (mm)	W (mm)	H (mm)	L1 (mm)	L2 (mm)	W1 (mm)	W2 (mm)	H1 (mm)	H2 (mm)
AQm37			240	132	155	28.5	80	100	79	63	112
AQm60	1"	1"	265	147	183	29.5	90	112	85	71	124.5
AQm75			275	147	183	28.5	90	112	88	71	129

Package Information

Model	GW (Kgs)	L (mm)	W (mm)	H (mm)	Quantity (PCS/20'TEU)
AQm37	6.1	277	158	174	3168
AQm60	9.8	337	190	210	1960
AQm75	10.8	350	190	210	1860

