



Application

- Can be used to transfer clean water or other liquids similar to water in physical and chemical properties
- Suitable for small living water supply, automatic water sprinkler system, small air conditioner system or supporting equipment etc.

Pump

- Special anti-rust treatment for cast iron pump body and support
- Anti-block system for impeller
- Brass impeller
- AISI 304 shaft
- Max. liquid temperature: +60°C
- Max. suction: +9 m
- Self-priming

Motor

- Low noise&Long life bearing
- Motor with copper winding
- Built-in thermal protector for single phase motor
- Insulation class: F
- Protection class: IPX4
- Max. ambient temperature: +40°C
- IE2 motor for APS110

Identification Codes

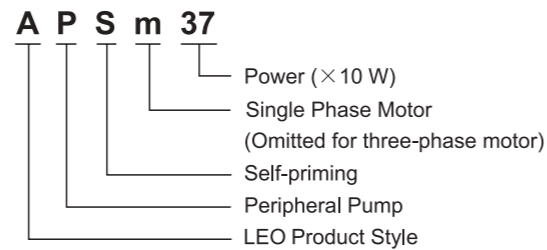

Technical Data

MODEL		POWER		Q (m³/h)																									
Single Phase	Three Phase	kW	HP	0	0.3	0.6	0.9	1.2	1.5	1.8	2.1	2.4	3.0	3.3	3.6	4.2	Q (l/min)												
				H (m)																									
				0	5	10	15	20	25	30	35	40	50	55	60	70	40	35	28	22	18	12	5	-	-	-	-	-	
APSm37	—	0.37	0.5	40	35	28	22	18	12	5	-	-	-	-	-	-	45	40	32	28	22	18	12	8	5	-	-	-	-
APSm60	—	0.6	0.8	55	50	42	38	32	28	22	18	12	5	-	-	-	65	60	55	50	45	40	35	30	25	20	15	10	5
APSm75	—	0.75	1.0																										
APSm110	APS110	1.1	1.5																										

Hydraulic Performance Curves

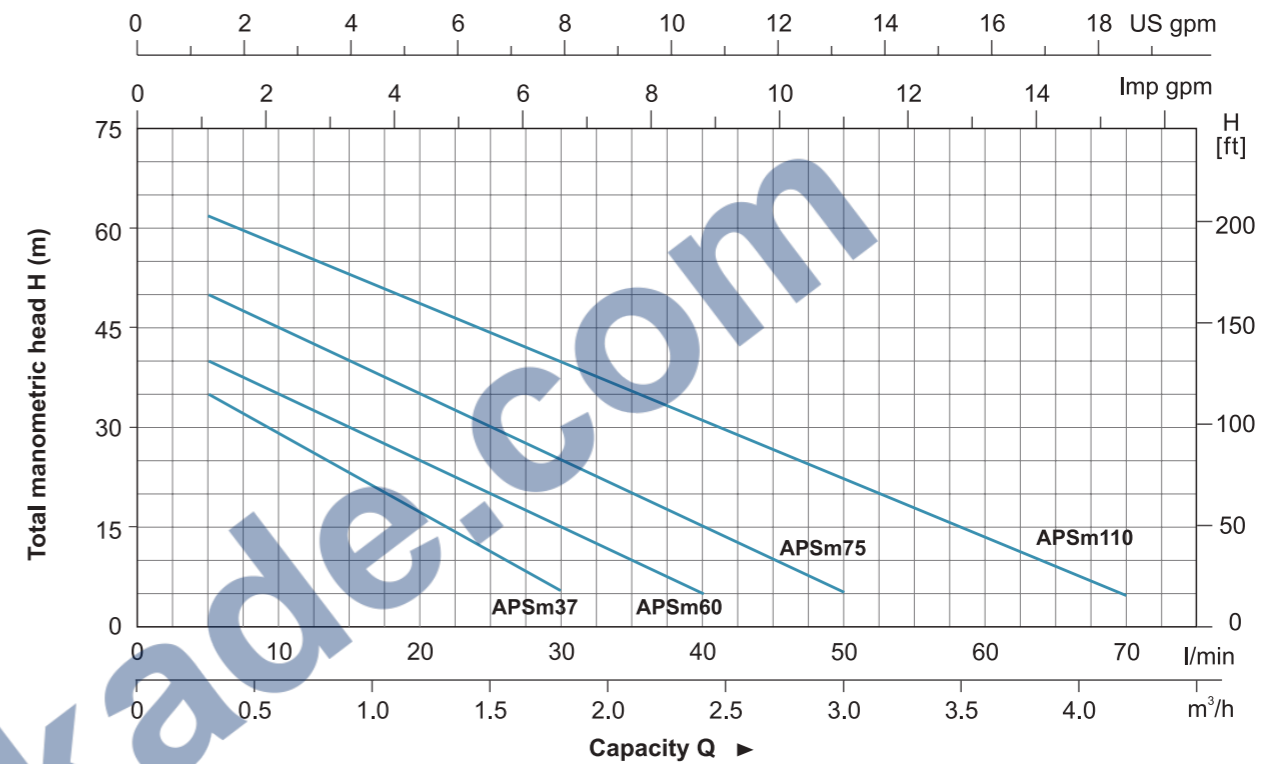

Materials Table

No.	Part	Material
1	Screw	Steel
2	Pump body	HT200
3	Impeller	Brass
4	Mechanical seal	Carbon/Ceramic
5	O-ring	NBR
6	Support	HT200
7	Bearing	
8	Rotor	
9	Fan cover	PP
10	Fan	PP
11	Rear cover	ZL102
12	Capacitor	
13	Terminal box	PA6-GF25
14	Stator	
15	Terminal board	PC
16	Non-return valve	NBR
17	Connector	HT200

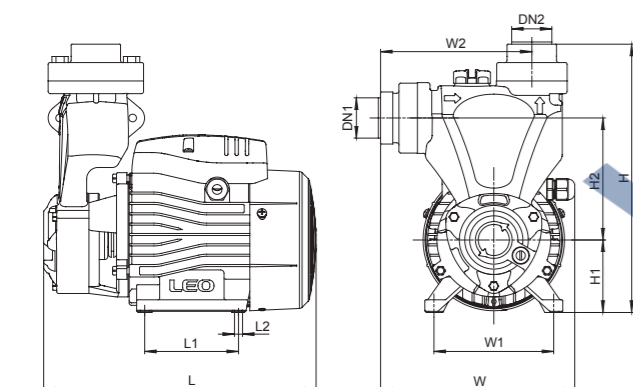
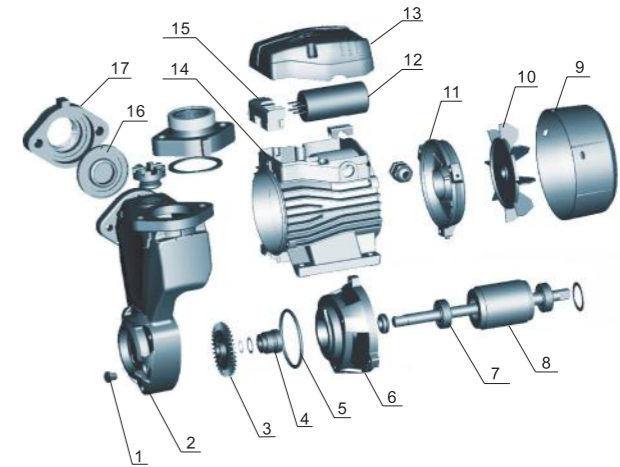

Dimension

Model	DN1	DN2	L (mm)	W (mm)	H (mm)	L ₁ (mm)	W ₁ (mm)	W ₂ (mm)	H ₁ (mm)	H ₂ (mm)	L ₂ (mm)
APSm37			239	170	234	80	100	128	63	106	8.5
APSm60	1"	1"	260	180	251	90	112	132	71	120	8.5
APSm75			270	180	260	90	112	142	71	130	8.5
APSm110	1 1/2"	1 1/2"	310	200	284	100	125	149	86	138	9

Package Information

Model	GW (Kgs)	L (mm)	W (mm)	H (mm)	Quantity (PCS/20 TEU)
APSm37	7.2	275	200	265	2040
APSm60	10.8	290	205	285	1736
APSm75	12.3	305	214	290	1365
APSm110	17.5	345	232	320	998



