



Application

- Can be used to transfer clean water or other liquids similar to water in physical and chemical properties
- Suitable for lifting water from the well, sprinkling irrigation in garden, pressure boosting of running water, and supporting equipment etc.

Pump

- Cast iron pump body and support under special anti-rust treatment
- Stainless steel impeller
- AISI 304 shaft
- Max. liquid temperature: +60°C
- Max. suction: +40 m

Motor

- Low noise&Long life bearing
- Motor with copper winding
- Built-in thermal protector for single phase motor
- Insulation class: F
- Protection class: IPX4
- Max. ambient temperature: +40°C

Identification Code

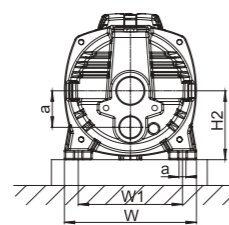
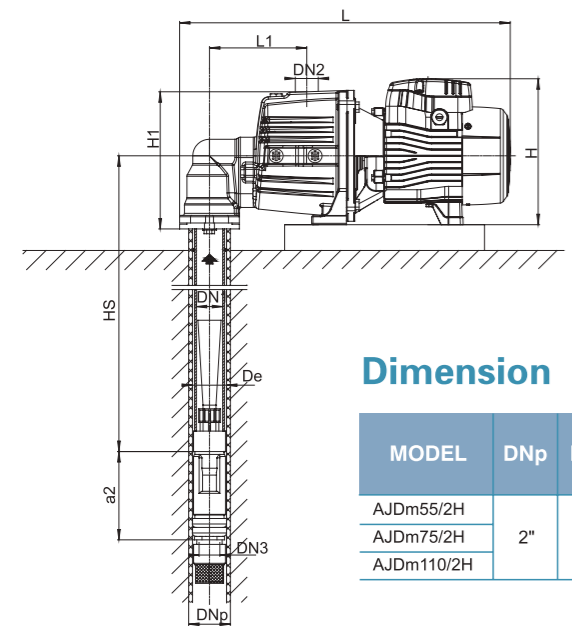
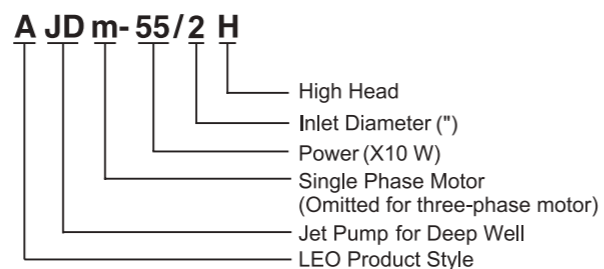

Dimension

MODEL	DNp	DN1	DN2	DN3	De	DIMENSIONS (mm)									
						L	H	W	L1	H1	H2	W1	a	a2	S
AJDm55/2H						476	212	190	140	204	110	150	53	128	10
AJDm75/2H	2"	1 1/4"	1"	1"	49	535	237	206	153	211	112	166			
AJDm110/2H															

Technical Data

MODEL	POWER (kW) (HP)	HS (m)	Q (l/min)	H (m)																									
				0	2	4	6	8	10	12	14	16	18	20	22	24	26	28	30										
AJDm55/2H	0.55	0.75	15	37	33	30	27	25	23	21	19	17	15	13	-	-	-	-	-	-	-	-	-	-	-	-	-	-	
AJDm75/2H	0.75	1	15	47	43	40	37	34	31	29	27	25	23	21	19	17	-	-	-	-	-	-	-	-	-	-	-	-	
AJDm110/2H	1.1	1.5	15	70	65	61	57	53	50	47	44	42	40	38	36	34	32	30	28	-	-	-	-	-	-	-	-	-	
AJDm55/2H	0.55	0.75	20	30	26	23	21	19	17	15	13	-	-	-	-	-	-	-	-	-	-	-	-	-	-	-	-	-	
AJDm75/2H	0.75	1	20	39	36	33	30	27	24	22	20	18	17	-	-	-	-	-	-	-	-	-	-	-	-	-	-	-	
AJDm110/2H	1.1	1.5	20	62	57	53	49	46	43	40	38	36	34	32	28	28	-	-	-	-	-	-	-	-	-	-	-	-	
AJDm55/2H	0.55	0.75	25	23	19	16	14	12	-	-	-	-	-	-	-	-	-	-	-	-	-	-	-	-	-	-	-	-	
AJDm75/2H	0.75	1	25	32	29	26	23	20	18	16	-	-	-	-	-	-	-	-	-	-	-	-	-	-	-	-	-	-	
AJDm110/2H	1.1	1.5	25	54	49	45	42	39	36	33	31	29	27	-	-	-	-	-	-	-	-	-	-	-	-	-	-	-	
AJDm55/2H	0.55	0.75	30	16	13	-	-	-	-	-	-	-	-	-	-	-	-	-	-	-	-	-	-	-	-	-	-	-	
AJDm75/2H	0.75	1	30	25	22	19	16	-	-	-	-	-	-	-	-	-	-	-	-	-	-	-	-	-	-	-	-	-	
AJDm110/2H	1.1	1.5	30	46	42	38	35	32	29	27	-	-	-	-	-	-	-	-	-	-	-	-	-	-	-	-	-	-	
AJDm55/2H	0.75	1	35	18	15	-	-	-	-	-	-	-	-	-	-	-	-	-	-	-	-	-	-	-	-	-	-	-	
AJDm75/2H	1.1	1.5	35	39	35	31	28	-	-	-	-	-	-	-	-	-	-	-	-	-	-	-	-	-	-	-	-	-	
AJDm110/2H	1.1	1.5	40	32	28	-	-	-	-	-	-	-	-	-	-	-	-	-	-	-	-	-	-	-	-	-	-	-	

Materials Table

No.	Part	Material	No.	Part	Material
1	Elbow	HT200	14	Ejector	HT200
2	Gasket seal	NBR	15	Sealing cup	NBR
3	Pump body	HT200	16	Copper sheathing	HPb59-1
4	Diffuser	PPO	17	Copper sleeve	HPb59-1
5	Impeller	AISI 304	18	Terminal box	PA6-GF25
6	Mechanical seal	Carbon/Ceramic	19	Terminal board	PC
7	O-ring	NBR	20	Stator	
8	Support cover	AISI 304/HT200	21	Motor foot	PA6
9	Support	ZL102	22	Capacitor	
10	Bearing		23	Cable holder	
11	Rotor		24	Rear cover	ZL102
12	Venturi tube	PPO	25	Fan	PP
13	Nozzle	PPO	26	Fan cover	PP

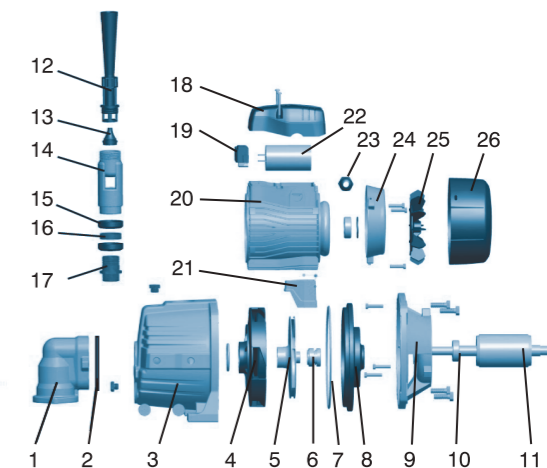

Package Information

MODEL	WG (kgs)	L (mm)	W (mm)	H (mm)	Quantity (PCS/20 TEU)
AJDm55/2H	15.65	500	215	240	1053
AJDm75/2H	16.9	500	215	240	1053
AJDm110/2H	21.95	585	230	265	728





Application

- Can be used to transfer clean water or other liquids similar to water in physical and chemical properties
- Suitable for lifting water from the well, sprinkling irrigation in garden, pressure boosting of running water, and supporting equipment etc.

Pump

- Cast iron pump body and support under special anti-rust treatment
- Stainless steel impeller
- AISI 304 shaft
- Max. liquid temperature: +60°C
- Max. suction: +40 m

Motor

- Low noise&Long life bearing
- Motor with copper winding
- Built-in thermal protector for single phase motor
- Insulation class: F
- Protection class: IPX4
- Max. ambient temperature: +40°C

Identification Code

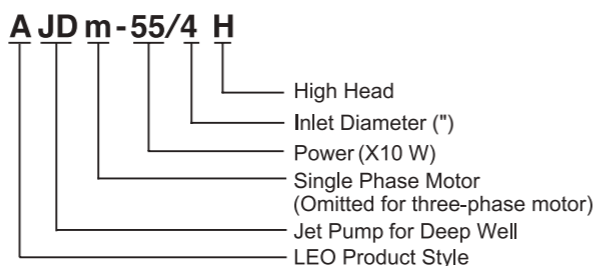

Technical Data

MODEL	POWER		HS (m)	Q (l/min)	H (m)																
	(kW)	(HP)			0	2	4	6	8	10	12	14	16	18	20	22	24	26	28	30	32
AJDm55/4H	0.55	0.75	15	39	35	33	29	27	25	23	21	19	17	15	14	13	-	-	-	-	-
AJDm75/4H	0.75	1			50	46	43	40	37	34	32	30	28	26	24	22	20	19	18	17	-
AJDm110/4H	1.1	1.5	20	75	70	66	62	58	55	52	49	47	45	43	41	39	37	35	33	31	29
AJDm55/4H	0.55	0.75			32	28	25	23	21	19	17	15	13	-	-	-	-	-	-	-	-
AJDm75/4H	0.75	1	25	42	39	36	33	30	27	25	23	21	20	18	17	-	-	-	-	-	-
AJDm110/4H	1.1	1.5			67	62	58	54	51	48	45	43	41	39	37	35	33	31	29	27	-
AJDm55/4H	0.55	0.75	30	25	21	18	16	14	12	-	-	-	-	-	-	-	-	-	-	-	-
AJDm75/4H	0.75	1			35	32	29	26	23	21	19	17	-	-	-	-	-	-	-	-	-
AJDm110/4H	1.1	1.5	35	59	54	50	47	44	41	38	36	34	32	30	28	-	-	-	-	-	-
AJDm55/4H	0.55	0.75			18	15	12	-	-	-	-	-	-	-	-	-	-	-	-	-	-
AJDm75/4H	0.75	1	40	28	25	22	19	17	-	-	-	-	-	-	-	-	-	-	-	-	-
AJDm110/4H	1.1	1.5			51	47	43	40	37	34	32	30	28	-	-	-	-	-	-	-	-
AJDm75/4H	0.75	1	40	21	18	16	-	-	-	-	-	-	-	-	-	-	-	-	-	-	-
AJDm110/4H	1.1	1.5			44	40	36	33	30	27	-	-	-	-	-	-	-	-	-	-	-
AJDm110/4H	1.1	1.5	40	37	33	30	27	-	-	-	-	-	-	-	-	-	-	-	-	-	-

Materials Table

No.	Part	Material	No.	Part	Material
1	Pump body	HT200	12	Ejector	HT200
2	Diffuser	PPO	13	Terminal box	PA6-GF25
3	Impeller	Stainless steel	14	Terminal board	PC
4	Mechanical seal	Carbon/Ceramic	15	Stator	
5	O-ring	NBR	16	Motor foot	PA6
6	Support cover	AISI 304/HT200	17	Capacitor	
7	Support	ZL102	18	Cable holder	
8	Bearing		19	Rear cover	ZL102
9	Rotor		20	Fan	PP
10	Venturi tube	PPO	21	Fan cover	PP
11	Nozzle	PPO			

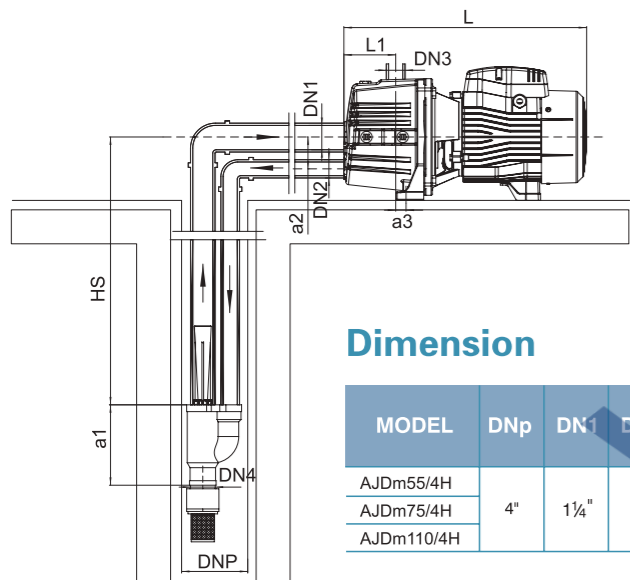
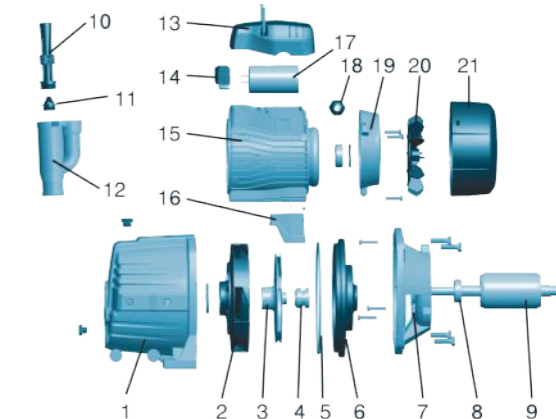

Dimension

MODEL	DNp	DN1	DN2	DN3	DN4	DIMENSIONS (mm)									
						L	L1	n	n1	H	h1	a1	a2	a3	S
AJDm55/4H	4"	1 1/4"	1"	1"	1"	370	77	190	150	212	100	160	53	17	10
AJDm75/4H						429	90	206	166	236	112				
AJDm110/4H						429	90	206	166	236	112				

Package Information

MODEL	WG (kgs)	L (mm)	W (mm)	H (mm)	Quantity (PCS/20 TEU)
AJDm55/4H	16.65	500	215	240	1053
AJDm75/4H	17.9	500	215	240	1053
AJDm110/4H	23.25	585	230	265	728

