



ACm
Centrifugal Pump



Application

- Can be used to transfer clean water or other liquids similar to water in physical and chemical properties
- Suitable for industrial use and urban water supply, pressure boosting for high buildings and fire fighting, garden irrigation, long-distance water transfer, heating ventilation and air controlling, circulation and pressure boosting for cold and hot water, and supporting equipment etc.

Pump

- Cast iron pump body and support under special anti-rust treatment
- AISI 304 shaft
- Max. liquid temperature: +60°C
- Max. suction: +8 m

Motor

- C&U bearing
- Motor with copper winding
- Built-in thermal protector for single phase motor
- Insulation class: F
- Protection class: IPX4
- Max. ambient temperature: +40°C
- IE 2 motor (Three phase, power ≥ 0.75kW)

Identification Codes

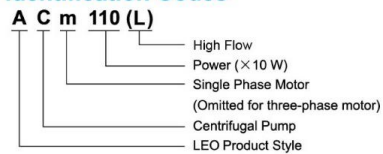

Technical Data

MODEL	POWER	Q (m³/h)																							
		0	0.6	0.9	1.2	1.8	2.4	3.0	3.6	4.2	4.5	4.8	5.4	6.0	6.6	7.2	7.8	8.4	9.0	9.6	10.3	11.7	12.6		
Single Phase	Three Phase	kW	HP	H (m)																					
ACm25	—	0.25	0.3	17	16.5	16.2	16	15.5	14.5	3.5	12.5	10.5	9.5	8	-	-	-	-	-	-	-	-	-		
ACm37	—	0.37	0.5	23	21.5	21	21	20.5	19.5	18	17	15.5	14.5	14	12	-	-	-	-	-	-	-	-		
ACm60	AC60	0.6	0.8	27	26.5	26.2	26	25	24.5	22.5	20	17	15.5	14	10	-	-	-	-	-	-	-	-		
ACm75	AC75	0.75	1.0	36	35	34	33.5	33	32	31	29	27	26	23.5	20	16	-	-	-	-	-	-	-		
ACm110	AC110	1.1	1.5	40	39	38	38	37.5	37	36	35	33	32	31	29	26	23	20	-	-	-	-	-		
ACm150	AC150	1.5	2	48	47.5	47	46.5	45.5	44.5	43.5	42.5	41.5	41	40.5	39	37	34.5	31	27	22	-	-	-		
—	AC220	2.2	3	55	54.5	53	53.5	53	52.5	51.5	50.5	49.5	48	48.5	47	45.5	43.5	40	36.5	32.5	28	-	-		
ACm110L	AC110L	1.1	1.5	34.5	34.3	34.2	34.1	34	33.8	33.5	33	32.5	32.3	32	31	30.5	29.5	28.5	27.5	26.5	25	23.5	20	16.5	
ACm150L	AC150L	1.5	2	37.5	37.2	37	36.9	36.6	36.2	35.8	35.4	35	34.8	34.7	34	33.3	32.5	31.5	30.5	29.5	28.2	27	24	21	19

Hydraulic Performance Curves

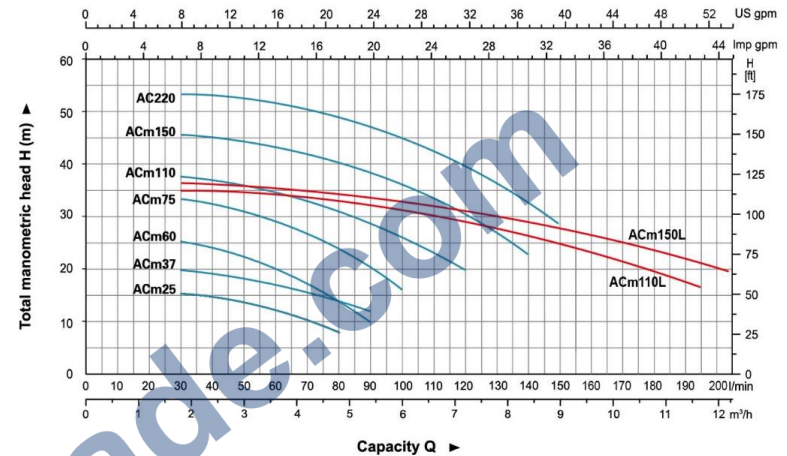

Materials Table

No.	Part	Material
1	Pump body	HT200
2	Impeller	AISI 304
3	O-ring	NBR
4	Mechanical seal	Carbon/Ceramic
5	Support cover	AISI 304/HT200
6	Support	ZL102
7	Terminal board	PC
8	Stator	—
9	Terminal box	ABS
10	Capacitor	—
11	Rotor	—
12	Bearing	—
13	Rear cover	ZL102
14	Fan	PP
15	Fan cover	PP

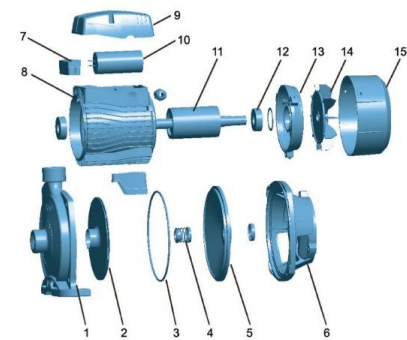

Dimension

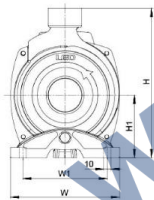
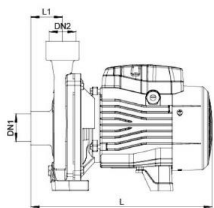

Model	DN1	DN2	L (mm)	W (mm)	H (mm)	L1 (mm)	W1 (mm)	H1 (mm)
ACm25	—	—	270	157	216	42	122	90
ACm37	—	—	270	157	216	42	122	90
ACm60	1"	1"	298	190	240	44	160	90
ACm75	—	—	298	190	240	44	160	100
ACm110	1 1/4"	1"	359	206	263	50	178	112
ACm150	—	—	360	240	286	51	207	115
AC220	—	—	360	240	286	51	207	115
ACm110L	1 1/2"	1"	356	206	265	48.5	178	112
ACm150L	—	—	356	206	265	48.5	178	112

Package Information

Model	GW (Kgs)	L (mm)	W (mm)	H (mm)	Quantity (PCS/20 TEU)
ACm25	7.9	290	185	239	2124
ACm37	8.4	290	185	239	2124
ACm60	11.5	333	215	260	1384
ACm75	13.4	333	215	260	1384
ACm110	18.45	383	233	287	987
ACm150	22.8	425	265	310	770
AC220	23.3	425	265	310	770
ACm110L	18.4	383	233	287	987
ACm150L	19.35	383	233	287	987





ACm
Centrifugal Pump



Application

- Can be used to transfer clean water or other liquids similar to water in physical and chemical properties
- Suitable for industrial use and urban water supply, pressure boosting for high buildings and fire fighting, garden irrigation, long-distance water transfer, heating ventilation and air controlling, circulation and pressure boosting for cold and hot water, and supporting equipment etc.

Pump

- Cast iron pump body and support under special anti-rust treatment
- AISI 304 shaft
- Max. liquid temperature: +60°C
- Max. suction: +8 m

Motor

- C&U bearing
- Motor with copper winding
- Insulation class: F
- Protection class: IPX4
- Max. ambient temperature: +40°C
- IE 2 motor (Three phase, power ≥ 0.75kW, AC750C2 and AC750C4 excluded)

Identification Codes

ACm 220 C (H) 2

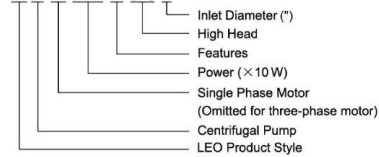

Technical Data

MODEL	POWER		Q (m³/h)												
	Single Phase	Three Phase	0	6	9	12	15	18	24	27	30	36	42	48	54
	kW	HP	Q (l/min)												
ACm220CH2	2.2	3	0	100	150	200	250	300	400	450	500	600	700	800	900
ACm300CH2	3	4	31	30	29.5	28.5	27.5	26	21.5	18.5	-	-	-	-	-
ACm400CH2	4	5.5	38	37.5	37	36	34.5	33	28.5	25.5	-	-	-	-	-
ACm550CH2	5.5	7.5	49	48	47	46	45	43.5	39.5	37	-	-	-	-	-
ACm300C2	3	4	54	52.5	52	51	50	49	46	44	42	-	-	-	-
ACm400C2	4	5	30	29.5	29	28.5	28	27	25	23.5	22	19.5	15.5	11.5	-
ACm550C2	5.5	7.5	39	38.5	38	37.5	37	36	34	32.5	31	28	24	18.5	13
AC750C2	7.5	10	46.5	45.5	45	44.5	43.5	42.5	40	38.5	37	33	28	22	15
AC750C4	7.5	10	56.5	55	55	54.5	53.5	52.5	50	48.5	46.5	42	36.5	30.5	20
AC750C4	7.5	10	52.5	52	52	51.5	51	50.5	48	46.5	44.5	40	35.5	30.5	24

Dimension

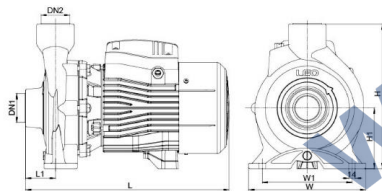

Model	DN1	DN2	L (mm)	W (mm)	H (mm)	L1 (mm)	W1 (mm)	H1 (mm)
ACm220CH2	2"	2"	444	255	315	65	186	132
ACm300CH2	2"	2"	444	255	315	65	186	132
ACm400CH2	2"	2"	496.5	280	326	70	195	136
AC550CH2	2"	2"	496.5	280	326	70	195	136
ACm300C2	2"	2"	444	255	315	65	186	132
ACm400C2	2"	2"	496.5	280	326	70	195	136
AC550C2	2"	2"	496.5	280	326	70	195	136
AC750C2	4"	3"	515	290	360	85	216	150
AC750C4	4"	3"	525	290	360	95	216	150

Hydraulic Performance Curves

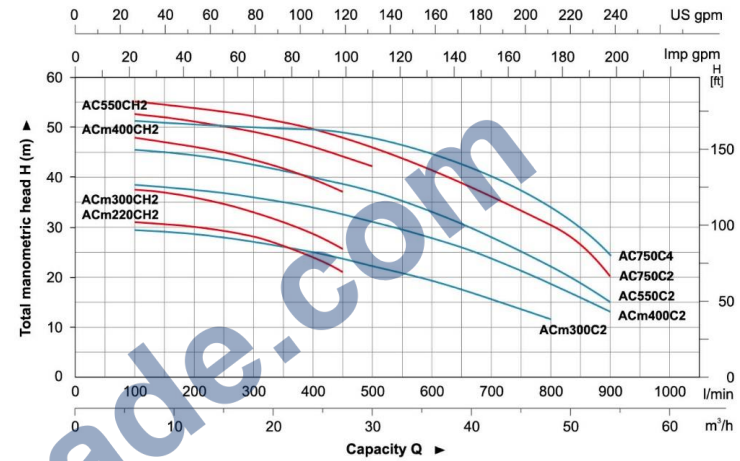

Materials Table

No.	Part	Material
1	Pump body	HT200
2	Impeller	AISI 304 Brass
3	Mechanical seal	Carbon/Ceramic
4	Bracket cover	HT200
5	Oil seal	
6	Support	HT200
7	Bearing	
8	Rotor	
9	Fan cover	PP
10	Fan	PP
11	Rear cover	ZL102
12	Stator	
13	Capacitor	
14	Terminal box	ABS

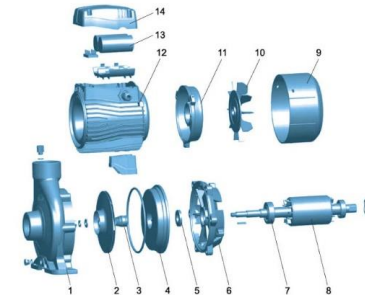

Package Information

Model	GW (Kgs)	L (mm)	W (mm)	H (mm)	Quantity (PCS/20 TEU)
ACm220CH2	39	507	304	372	486
ACm300CH2	41.8	507	304	372	478
ACm400CH2	56.5	562	328	383	345
AC550CH2	57.1	562	328	383	345
ACm300C2	41.4	507	304	372	483
ACm400C2	57.5	562	328	372	345
AC550C2	55.5	562	328	383	345
AC750C2	62	587	338	417	305
AC750C4	63.7	587	338	417	305





ACm
Centrifugal Pump



Application

- Can be used to transfer clean water or other liquids similar to water in physical and chemical properties
- Suitable for industrial use and urban water supply, pressure boosting for high buildings and fire fighting, garden irrigation, long-distance water transfer, heating ventilation and air controlling, circulation and pressure boosting for cold and hot water, and supporting equipment etc.

Pump

- Cast iron pump body and support under special anti-rust treatment
- AISI 304 shaft
- Max. liquid temperature: +60°C
- Max. suction: +8 m

Motor

- C&U bearing
- Motor with copper winding
- Built-in thermal protector for single phase motor
- Insulation class: F
- Protection class: IPX4
- Max. ambient temperature: +40°C
- IE 2 motor (Three phase, power ≥ 0.75kW)

Identification Codes

A C m 110 B 2

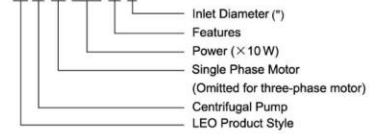

Hydraulic Performance Curves

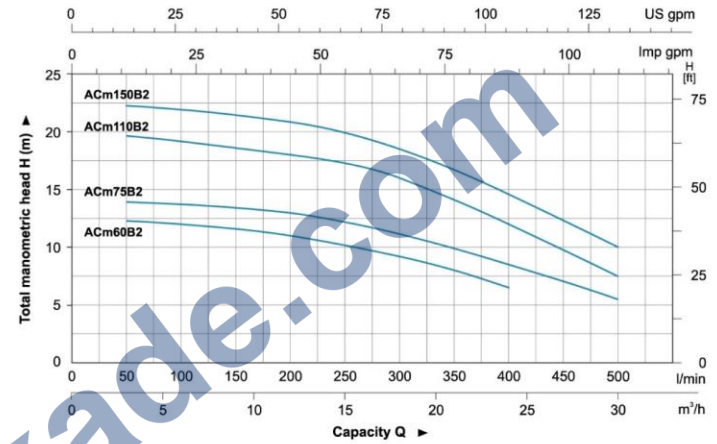

Materials Table

No.	Part	Material
1	Pump body	HT200
2	Impeller	AISI 304 FRS
3	Mechanical seal	Carbon/Ceramic
4	Support cover	HT200
5	Oil seal	
6	Support	ZL102
7	Bearing	
8	Rotor	
9	Terminal box	ABS
10	Stator	
11	Capacitor	
12	Rear cover	ZL102
13	Fan	PP
14	Fan cover	PP

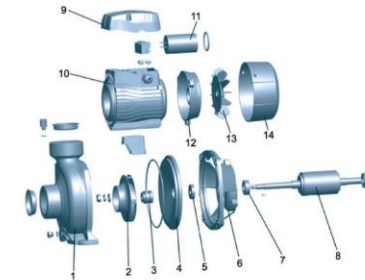

Technical Data

MODEL	POWER		Q (m ³ /h)																																																																																						
	Single Phase	Three Phase	0	6	9	12	15	18	21	24	30																																																																														
ACm60B2	AC60B2	0.6 0.8	<table border="1"> <thead> <tr> <th colspan="2">Q (l/min)</th> <th colspan="10">H (m)</th> </tr> <tr> <th>0</th><th>100</th><th>150</th><th>200</th><th>250</th><th>300</th><th>350</th><th>400</th><th>500</th><th colspan="2"></th><th colspan="2"></th> </tr> </thead> <tbody> <tr><td>12.5</td><td>12</td><td>11.7</td><td>11</td><td>10.2</td><td>9.2</td><td>8</td><td>6.5</td><td>-</td><td colspan="2"></td><td colspan="2"></td></tr> <tr><td>14</td><td>13.7</td><td>13.5</td><td>13</td><td>12.3</td><td>11.2</td><td>9.9</td><td>8.5</td><td>5.5</td><td colspan="2"></td><td colspan="2"></td></tr> <tr><td>19.5</td><td>19.2</td><td>19</td><td>18.5</td><td>17.7</td><td>16.5</td><td>15</td><td>13</td><td>8.5</td><td colspan="2"></td><td colspan="2"></td></tr> <tr><td>22</td><td>21.5</td><td>21</td><td>20.5</td><td>19.5</td><td>18.3</td><td>16.5</td><td>14.5</td><td>9.5</td><td colspan="2"></td><td colspan="2"></td></tr> </tbody> </table>										Q (l/min)		H (m)										0	100	150	200	250	300	350	400	500					12.5	12	11.7	11	10.2	9.2	8	6.5	-					14	13.7	13.5	13	12.3	11.2	9.9	8.5	5.5					19.5	19.2	19	18.5	17.7	16.5	15	13	8.5					22	21.5	21	20.5	19.5	18.3	16.5	14.5	9.5				
Q (l/min)		H (m)																																																																																							
0	100	150											200	250	300	350	400	500																																																																							
12.5	12	11.7											11	10.2	9.2	8	6.5	-																																																																							
14	13.7	13.5											13	12.3	11.2	9.9	8.5	5.5																																																																							
19.5	19.2	19	18.5	17.7	16.5	15	13	8.5																																																																																	
22	21.5	21	20.5	19.5	18.3	16.5	14.5	9.5																																																																																	
ACm75B2	AC75B2	0.75 1																																																																																							
ACm110B2	AC110B2	1.1 1.5																																																																																							
ACm150B2	AC150B2	1.5 2																																																																																							

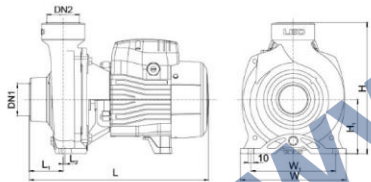

Dimension

Model	DN1	DN2	L (mm)	W (mm)	H (mm)	L ₁ (mm)	L ₂ (mm)	W ₁ (mm)	H ₁ (mm)
ACm60B2	2"	2"	331	195	242	62.5	4	156	100
ACm75B2	2"	2"	331	195	242	62.5	4	156	100
ACm110B2	2"	2"	378	206	263	59	3.5	166	112
ACm150B2	2"	2"	378	206	263	59	3.5	166	112

Package Information

Model	GW (Kgs)	L (mm)	W (mm)	H (mm)	Quantity (PCS/20 TEU)
ACm60B2	14.4	375	214	265	1264
ACm75B2	15.2	375	214	265	1264
ACm110B2	19.9	415	225	285	945
ACm150B2	20.7	415	225	285	945





ACm
Centrifugal Pump



Application

- Can be used to transfer clean water or other liquids similar to water in physical and chemical properties
- Suitable for industrial use and urban water supply, pressure boosting for high buildings and fire fighting, garden irrigation, long-distance water transfer, heating ventilation and air controlling, circulation and pressure boosting for cold and hot water, and supporting equipment etc.

Pump

- Cast iron pump body and support under special anti-rust treatment
- AISI 304 shaft
- Max. liquid temperature: +60°C
- Max. suction: +8 m

Motor

- C&U bearing
- Motor with copper winding
- Built-in thermal protector for single phase motor (≤1.5 kW)
- Insulation class: F
- Protection class: IPX4
- Max. ambient temperature: +40°C
- IE 2 motor (Three phase, power ≥ 0.75kW)

Identification Codes

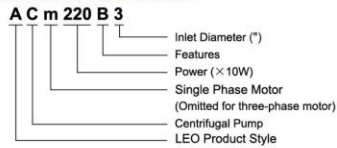

Technical Data

MODEL	POWER		Q (m³/h)											
	Three Phase	HP	0	12	18	24	30	36	42	48	54	60	66	71
ACm110B3	AC110B3	1.1	1.5	12.5	12.5	12.1	11.5	10.5	9.5	8.4	7.1	5.5	-	-
ACm110B4	AC110B4	1.1	1.5	12.5	12.5	12.1	11.5	10.5	9.5	8.4	7.1	5.5	-	-
ACm150B3	AC150B3	1.5	2	14.5	14.3	14	13.5	12.8	12	11.2	9.9	8.4	6	-
ACm150B4	AC150B4	1.5	2	14.5	14.3	14	13.5	12.8	12	11.2	9.9	8.4	6	-
ACm220B3	AC220B3	2.2	3	17.5	17.3	17.1	16.5	16	15.2	14.2	13.2	11.7	10	7.2
ACm220B4	AC220B4	2.2	3	17.5	17.3	17.1	16.5	16	15.2	14.2	13.2	11.7	10	7.2
ACm300B3	AC300B3	3	4	20	19.8	19.6	19.5	19	18.3	17.5	16.2	14.6	13	11.5
ACm300B4	AC300B4	3	4	20	19.8	19.6	19.5	19	18.3	17.5	16.2	14.6	13	11.5

Dimension

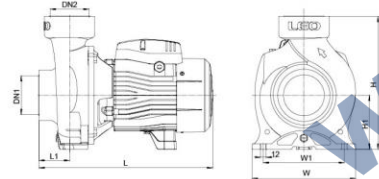

Model	DN	DN1	L (mm)	W (mm)	H (mm)	L1 (mm)	W1 (mm)	H1 (mm)
ACm110B3	3"	3"	386	230	295	68	180	120
ACm110B4	4"	4"	393	230	295	75	180	120
ACm150B3	3"	3"	386	230	295	68	180	120
ACm150B4	4"	4"	393	230	295	75	180	120
ACm220B3	3"	3"	453	230	295	68	180	120
ACm220B4	4"	4"	460	230	295	75	180	120
ACm300B3	3"	3"	453	230	295	68	180	120
ACm300B4	4"	4"	460	230	295	75	180	120

Hydraulic Performance Curves

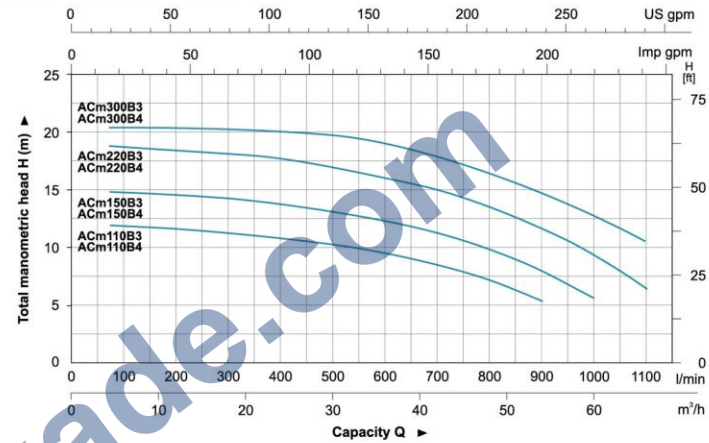

Materials Table

No.	Part	Material
1	Filling plug	HP689-T
2	Pump body	HT200
3	Impeller	Brass
4	O-ring	NBR
5	Mechanical seal	Carbon/Ceramic
6	Bracket cover	HT200
7	Oil seal	
8	Support	HT200
9	Bearing	
10	Rotor	
11	Terminal board	PC
12	Capacitor	
13	Terminal box	ABS
14	Stator	
15	Rear cover	ZL102
16	Fan	PP
17	Fan cover	PP

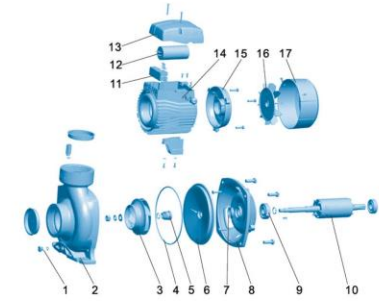

Package Information

Model	GW (Kgs)	L (mm)	W (mm)	H (mm)	Quantity (PCS/20 TEU)
ACm110B3	26.3	433	255	332	684
ACm110B4	29.5	433	255	332	675
ACm150B3	27.2	433	255	332	684
ACm150B4	30.4	433	255	332	655
ACm220B3	34.8	522	288	331	510
ACm220B4	38	522	288	331	496
ACm300B3	37.3	522	288	331	506
ACm300B4	40.5	522	288	331	467





ACm
Centrifugal Pump



Application

- Can be used to transfer clean water or other liquids similar to water in physical and chemical properties
- Suitable for industrial use and urban water supply, pressure boosting for high buildings and fire fighting, garden irrigation, long-distance water transfer, heating ventilation and air controlling, circulation and pressure boosting for cold and hot water, and supporting equipment etc.

Pump

- Cast iron pump body and support under special anti-rust treatment
- AISI 304 shaft
- Max. liquid temperature: +60°C
- Max. suction: +8 m

Motor

- C&U bearing
- Motor with copper winding
- Built-in thermal protector for single phase motor (≤1.5 kW)
- Insulation class: F
- Protection class: IPX4
- Max. ambient temperature: +40°C
- IE 2 motor (Three phase, power ≥ 0.75kW)

Identification Codes

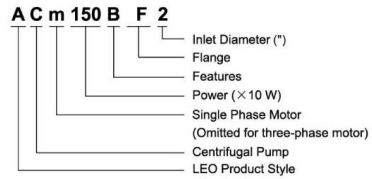

Technical Data

MODEL	POWER		Q (m ³ /h)															
	Single Phase	Three Phase	kW	HP	0	12	18	24	30	36	42	48	54	60	66	72	84	96
ACm110BF2	AC110BF2	1.1	1.5	19.5	18.5	16.5	13	8.5	-	-	-	-	-	-	-	-	-	-
ACm110BF3	AC110BF3	1.1	1.5	12.5	12.5	21.1	11.5	10.5	9.5	8.4	7.1	5.5	-	-	-	-	-	-
ACm150BF2	AC150BF2	1.5	2	22	20.5	18.3	14.5	9.5	-	-	-	-	-	-	-	-	-	-
ACm150BF3	AC150BF3	1.5	2	14.5	14.3	14	13.5	12.8	12	11.2	9.9	8.4	6	-	-	-	-	-
ACm220BF3	AC220BF3	2.2	3	17.5	17.3	17.1	16.5	16	15.2	14.2	14.2	11.7	10	7.2	-	-	-	-
ACm400BF4	AC400BF4	4	5.5	16.5	-	-	16	15.8	15.5	15.3	15	14.7	14.4	14	13.2	12.1	-	-

Hydraulic Performance Curves

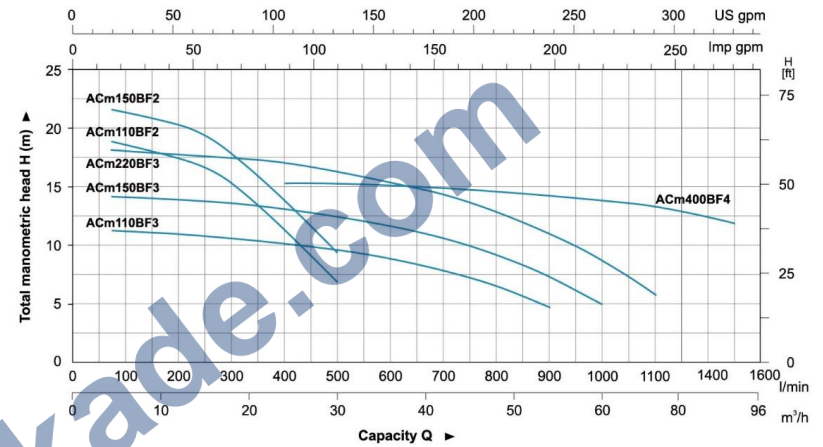

Materials Table

No.	Part	Material
1	Flange	HT200
2	Pump body	HT200
3	Impeller	AISI 304/Brass HT200
4	Mechanical seal	Carbon/Generic
5	Oil seal	
6	Support	HT200
7	Bearing	
8	Rotor	
9	Fan cover	PP
10	Fan	PP
11	Rear cover	HT200
12	Stator	
13	Capacitor	
14	Terminal box	PC/ABS

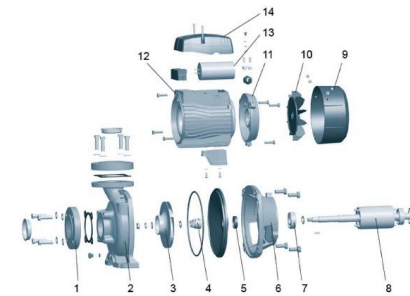

Dimension

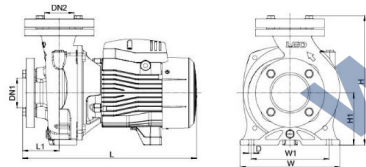

Model	DN1	DN2	L (mm)	W (mm)	H (mm)	L ₁ (mm)	W ₁ (mm)	H ₁ (mm)	D (mm)
ACm110BF2	2"	2"	392	206	270	64.5	166	112	10
ACm110BF3	3"	3"	403	230	300	86	180	120	12
ACm150BF2	2"	2"	392	206	270	64.5	166	112	10
ACm150BF3	3"	3"	403	230	300	86	180	120	12
ACm220BF3	3"	3"	471	230	300	86	180	120	12
ACm400BF4	4"	4"	593	281.5	398	120.5	206	160	16

Package Information

Model	GW (Kgs)	L (mm)	W (mm)	H (mm)	Quantity (PCS/20 TEU)
ACm110BF2	22.2	414	230	300	900
ACm150BF2	24	414	230	300	833
ACm110BF3	31.5	433	255	332	634
ACm150BF3	32.5	433	255	332	615
ACm220BF3	40	522	288	332	500
ACm400BF4	72.8	658	330	457	204

